

SERVICE MANUAL

CD STEREO SYSTEM

BASIC CD MECHANISM : BZG-2 ZD9GNC1

BASIC TAPE MECHANISM : CMAT6Z2(1+1)ALPS

SYSTEM	CD CASSEIVER	SPEAKER	REMOTE CONTROLLER
NSX-R20	CX-NR20	SX-NR20	RC-CAS03(VS)
NSX-R21	CX-NR21		

If requiring information about the CD mechanism, see Service Manual of BZG-2, (S/M Code No. 09-023-353-2N8).

TABLE OF CONTENTS

SPECIFICATIONS	3
PROTECTION OF EYES FROM LASER BEAM DURING SERVICING	4
NOTE ON BEFORE STARTING REPAIR	5, 6
ACCESSORIES PARTS LIST -1/1	7
ELECTRICAL PARTS LIST	8 ~ 21
TRANSISTOR ILLUSTRATION	22
SCHEMATIC DIAGRAM -1/4 (MAIN-1/2, DECK/AMP/HP SECTION)	23
SCHEMATIC DIAGRAM -2/4 (MAIN-2/2, TUNER SECTION)	24
WIRING -1/4 (MAIN C.B, HP C.B)	25
SCHEMATIC DIAGRAM -3/4 (FRONT/DECK SECTION)	26
WIRING -2/4 (FRONT C.B)	27
WIRING -3/4 (DECK C.B)	28
SCHEMATIC DIAGRAM -4/4 (POWER SECTION)	29
WIRING -4/4 (POWER C.B)	30
ELECTRICAL ADJUSTMENT	31 ~ 37
LCD DISPLAY -1/1	38
IC BLOCK DIAGRAM	39 ~ 41
IC DESCRIPTION	42 ~ 43
MECHANICAL EXPLODED VIEW -1/1	44
MECHANICAL PARTS LIST -1/1	45
COLOR NAME TABLE	46
TAPE MECHANISM EXPLODED VIEW -1/1 <CMAT6Z2 (1+1) ALPS>	47
CD TEST MODE	48
TAPE MECHANISM PARTS LIST -1/1 <CMAT6Z2 (1+1) ALPS>	49
GENERAL SPEAKER DISASSEMBLY INSTRUCTIONS (FOR REFERENCE) -1/1	50
SPEAKER PARTS LIST -1/1 (SX-NR20)	51
OTHER PARTS LIST -1/1	52

SPECIFICATIONS

MAIN UNIT (CX-NR20/CX-NR21)

TUNER

FM tuning range	87.5 MHz to 108 MHz
FM usable sensitivity (IHF)	16.8 dBf
FM antenna terminal	75 ohms (unbalanced)
MW tuning range	531 kHz to 1602 kHz (9 kHz step) 530 kHz to 1710 kHz (10 kHz step)
MW usable sensitivity	350 μ V/m
LW tuning range	144 kHz to 290 kHz
LW usable sensitivity	1400 μ V/m
MW/LW antenna	Loop antenna

AMPLIFIER

Power output	Rated: 20 W + 20 W (6 ohms, T.H.D. 1 %, 1 kHz/DIN 45500) Reference: 25 W + 25 W (6 ohms, T.H.D. 10 %, 1 kHz/DIN 45324)
Total harmonic distortion	0.08 % (13 W, 1 kHz, 6 ohms, DIN AUDIO)
Input	VIDEO/AUX: 500 mV
Outputs	SPEAKERS: 6 ohms or more PHONES: 32 ohms or more

CASSETTE DECK

Track format	4 tracks, 2 channels stereo
Frequency response	50 Hz – 15 kHz
Recording system	AC bias
Heads	DECK 1: playback x 1 DECK 2: recording/playback x 1, erase x 1

CD PLAYER

Laser	Semiconductor laser ($\eta = 780$ nm)
D/A converter	1 bit dual
Signal-to-noise ratio	85 dB (1 kHz, 0 dB)
Harmonic distortion	0.05 % (1 kHz, 0 dB)

GENERAL

Power requirements	230 V AC, 50 Hz
Power consumption	62 W
Power consumption in standby mode	With ECO mode on: 0.6 W With ECO mode off: 20 W
Dimensions (W x H x D)	260 x 324 x 315 mm
Weight	5.5 kg

FRONT SPEAKERS SX-NR20

Speaker system	3 way, bass reflex (magnetic shielded)
Speaker units	Woofer: 120 mm cone Tweeter: 60 mm ceramic Super tweeter: 20 mm ceramic
Impedance	6 ohms
Dimensions (W x H x D)	210 x 324 x 215 mm
Weight	3.0 kg

Specifications and external appearance are subject to change without notice.

PROTECTION OF EYES FROM LASER BEAM DURING SERVICING

This set employs laser. Therefore, be sure to follow carefully the instructions below when servicing.

WARNING!!

WHEN SERVICING, DO NOT APPROACH THE LASER EXIT WITH THE EYE TOO CLOSELY. IN CASE IT IS NECESSARY TO CONFIRM LASER BEAM EMISSION. BE SURE TO OBSERVE FROM A DISTANCE OF MORE THAN 30cm FROM THE SURFACE OF THE OBJECTIVE LENS ON THE OPTICAL PICK-UP BLOCK.

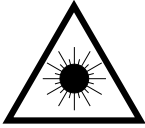

Caution: Invisible laser radiation when open and interlocks defeated avoid exposure to beam.

Advarsel: Usynlig laserstråling ved åbning, når sikkerhedsafbrydere er ude af funktion. Undgå udsættelse for stråling.

VAROITUS!

Laiteen Käyttäminen muulla kuin tässä käyttöohjeessa mainitulla tavalla saattaa altistaa käyttäjän turvallisuusluokan 1 ylittävälle näkymättömälle lasersäteilylle.

WARNING!

Om apparaten används på annat sätt än vad som specificeras i denna bruksanvisning, kan användaren utsättas för osynlig laserstrålning, som överskrider gränsen för laserklass 1.

CAUTION

Use of controls or adjustments or performance of procedures other than those specified herein may result in hazardous radiation exposure.

ATTENTION

L'utilisation de commandes, réglages ou procédures autres que ceux spécifiés peut entraîner une dangereuse exposition aux radiations.

ADVARSEL

Usynlig laserstråling ved åbning, når sikkerhedsafbrydere er ude af funktion. Undgå udsættelse for stråling.

This Compact Disc player is classified as a CLASS 1 LASER product.

The CLASS 1 LASER PRODUCT label is located on the rear exterior.

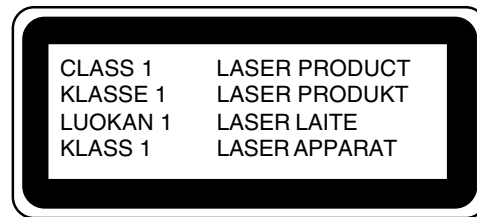

Precaution to replace Optical block (BZG-6 YANC)

(PXR-104X-BP-0101)

Body or clothes electrostatic potential could ruin laser diode in the optical block. Be sure ground body and workbench, and use care the clothes do not touch the diode.

1) After the connection, remove solder shown in right figure.

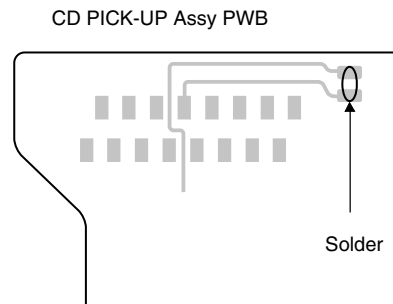

NOTE ON BEFORE STARTING REPAIR -1/2

1. Forced discharge of electrolytic capacitor of power supply block

When repair is going to be attempted in the set that uses relay circuit in the power supply block, electric potential is kept charged across the electrolytic capacitors (C101, 102) even though AC power cord is removed. If repair is attempted in this condition, secondary defect can occur. In order to prevent the secondary trouble, perform the following measures before starting repair work.

Discharge procedure

- ① Remove the AC power cord.
- ② Connect a discharging resistor at an end of lead wire that has clips at both ends. Connect the other end of the lead wire to metal chassis.
- ③ Contact the other end of the discharging resistor to the positive (+) side (+VH) of C101. (For two seconds)
- ④ Contact the same end of the discharging resistor as step ③ to the negative (-) side (-VH) of C102 in the same way. (For two seconds)
- ⑤ Check that voltage across C101 and C102 has decreased to 1 V or less using a multimeter or an oscilloscope.

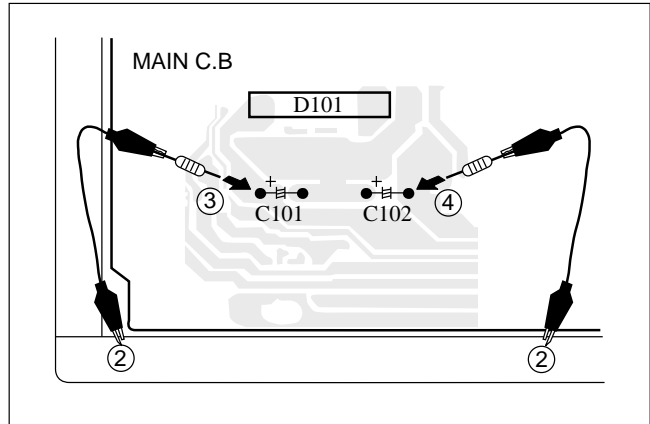

Fig-1

Select a discharging resistor referring to the following table.

Charging voltage (V) (C101, 102)	Discharging resistor (Ω)	Rated power (W)	Parts number
25-48	100	3	87-A00-247-090
49-140	220	5	87-A00-232-090

Note: The reference numbers (C101, C102) of the electrolytic capacitors can change depending on the models. Be sure to check the reference numbers of the charging capacitors on schematic diagram before starting the discharging work.

2. Check items before exchanging the MICROCOMPUTER

Be sure to check the following items before exchanging the MICROCOMPUTER. Exchange the MICROCOMPUTER after confirming that the MICROCOMPUTER is surely defective.

2-1. Regarding the HOLD terminal of the MICROCOMPUTER

When the HOLD terminal (INPUT) of the MICROCOMPUTER is "H", the MICROCOMPUTER is judged to be operating correctly.

When this terminal is "L", the main power cannot be turned on. Therefore, be sure to check the terminal voltage of the HOLD terminal before exchange.

When the MICROCOMPUTER is not defective, the HOLD terminal can also go "L" when the POWER AMPLIFIER has any abnormalities that triggers the abnormality detection circuit on the MAIN C. B. that sets the HOLD terminal to "L".

- Good or no good judgement of the MICROCOMPUTER

- ① Turn on the AC main power.
- ② Confirm that the main power is turned on and the HOLD terminal of the MICROCOMPUTER keeps the "H" level or not.
- ③ When the HOLD terminal is "L" level, the abnormality detection circuit is judged to be working correctly and the MICROCOMPUTER is judged to be good.

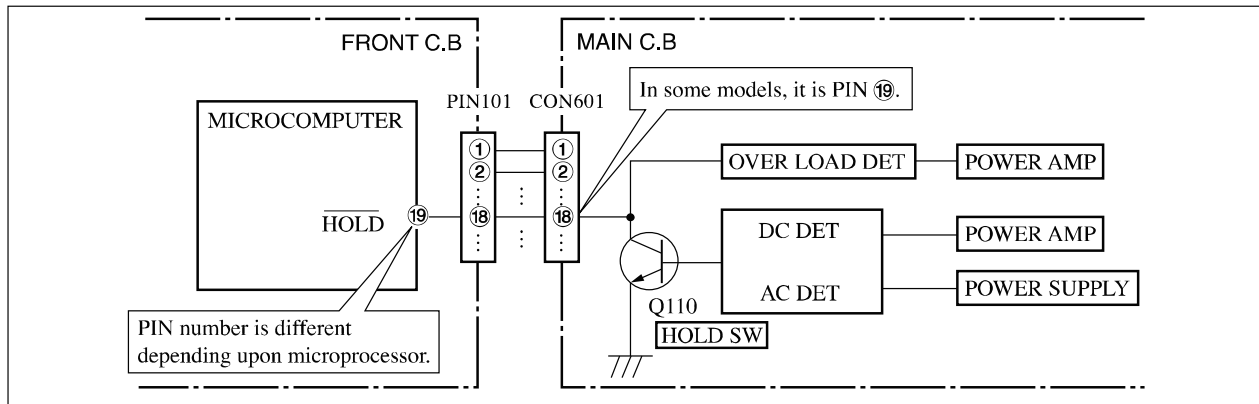

Fig-2-1

NOTE ON BEFORE STARTING REPAIR -2/2

In such a case, check also if the POWER AMPLIFIER circuit or power supply circuit has any abnormalities or not.

2-2. Regarding reset

There are cases that the machine does not work correctly because the MICROCOMPUTER is not reset even though the AC power cord is re-inserted, or the software reset (pressing the STOP key + POWER key) is performed.

When the above described phenomenon occurs, it can lead to wrong judgement as if the MICROCOMPUTER is defective and to exchange the MICROCOMPUTER. In such a case, perform the forced-reset by the following procedure and check good or no good of the MICROCOMPUTER.

- ① Remove the AC power cord.

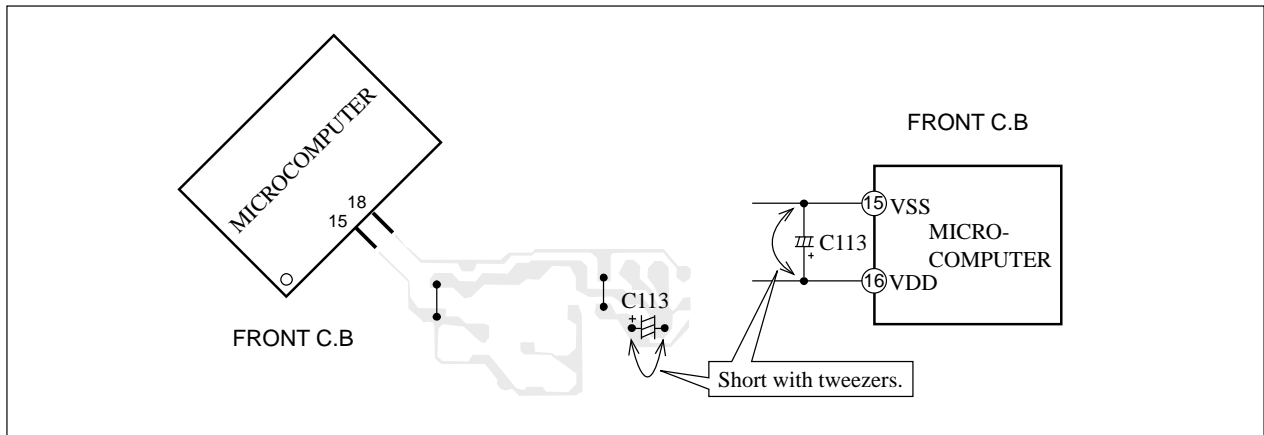

Fig-2-2

- ② Short both ends of the electrolytic capacitor C113 that is connected to VDD of the MICROCOMPUTER with tweezers.
- ③ Connect the AC power cord again. If the MICROCOMPUTER returns to the normal operation, the MICROCOMPUTER is good.

Note: The reference number or MICROCOMPUTER pin number of transistor (Q110) and electrolytic capacitor (C113) can change depending on the models. Be sure to check the reference numbers on schematic diagram before starting the discharging work.

2-3. Confirmation of soldering state of MICROCOMPUTER

Check the soldering state of the MICROCOMPUTER in addition to the above described procedures. Be sure to exchange the MICROCOMPUTER after surely confirming that the trouble is not caused by poor soldering but the MICROCOMPUTER itself.

ACCESSORIES PARTS LIST -1/1

- ! = Δ SAFTY PARTS
- C = Components marked

All components used on this model at the production line are shown in this service manual.
 However, please note that not all components will be available as spare parts for after-sales service.
 Components marked S and O are designated as spare parts for service and will be stocked at the spare parts centers.
 Components marked X and R are not designated as spare parts for after sales service, and will not be stocked at the spare parts centers.

UNIT-NAME	! C	REF-NO	PARTS-NO	PARTS-NAME	SUFFIX&MODEL	
					CX - SNR21 EZSC1	CX - SNR20 KSC1
	O	AS1001	8C-NF9-906-010	IB, EZ (9L) S NSX-R21	a	.
	O	AS1001	8C-NF9-905-010	IB, K(E) S NSX-R20	.	b
	O	AS1002	8C-NF8-702-010	RC UNIT, RC-CAS03 (VS)	a	b
	O	AS1003	87-A92-150-010	ANT, LOOP AM NO-CONT	a	b
	O	AS1004	87-A92-346-010	ANT, WIRE FM (FASTEN)	a	b
	O	AS1005	87-099-811-010	PLUG, ADPTR CONV (K)	.	b

ELECTRICAL PARTS LIST - 1/14

! = ⚠ SAFTY PARTS
 C = Components marked

All components used on this model at the production line are shown in this service manual.
 However, please note that not all components will be available as spare parts for after-sales service.
 Components marked S and O are designated as spare parts for service and will be stocked at the spare parts centers.
 Components marked X and R are not designated as spare parts for after sales service, and will not be stocked at the spare parts centers.

UNIT-NAME	! C	REF-NO	PARTS-NO	PARTS-NAME	SUFFIX&MODEL	CX-SNR21	CX-SNR20
						EZSC1	KSC1
FRONT	O	C	0108 87-010-785-080	C-CAP,U 0.015-25 K B GRM	a		b
FRONT	O	C	0153 87-010-787-080	C-CAP,U 0.022-25 K B GRM	a		b
FRONT	O	C	0154 87-010-246-040	CAP,E 47-35 M 11L SME	a		b
FRONT	O	C	0155 87-010-404-040	CAP,E 4.7-50 M 11L SME	a		b
FRONT	O	C	0156 87-010-404-040	CAP,E 4.7-50 M 11L SME	a		b
FRONT	O	C	0301 87-012-278-080	C-CAP,U 2200P-50 K B GRM	a		b
FRONT	O	C	0351 87-A10-353-080	C-CAP,U 0.22-10 K B	a		b
FRONT	O	C	0361 87-012-274-080	C-CAP,U 1000P-50 K B GRM	a		b
FRONT	O	C	0362 87-012-274-080	C-CAP,U 1000P-50 K B GRM	a		b
FRONT	O	C	0371 87-012-274-080	C-CAP,U 1000P-50 K B GRM	a		b
FRONT	O	C	0372 87-012-274-080	C-CAP,U 1000P-50 K B GRM	a		b
FRONT	O	C	0601 87-010-382-040	CAP,E 22-25 M 11L SME	a		b
FRONT	O	C	0801 87-A10-353-080	C-CAP,U 0.22-10 K B	a		b
FRONT	O	C	0803 87-012-280-080	C-CAP,U 3300P-50 K B GRM	a		b
FRONT	O	C	0804 87-A10-592-080	C-CAP,S 0.015-50 J B	a		b
FRONT	O	C	0806 87-012-273-080	C-CAP,U 820P-50 K B GRM	a		b
FRONT	O	C	0808 87-010-544-040	CAP,E 0.1-50 M 11L SME	a		b
FRONT	O	C	0809 87-010-404-040	CAP,E 4.7-50 M 11L SME	a		b
FRONT	O	C	0810 87-010-759-080	C-CAP,U 0.1-25 Z F CM/CB	a		b
FRONT	O	C	0811 87-A12-052-080	C-CAP,S 0.033-25 J B	a		b
						EZSC1	KSC1
FRONT	O	C	0812 87-012-285-080	C-CAP,U 8200P-50 K B GRM	a		b
FRONT	O	C	0901 87-012-195-080	C-CAP,U 100P-50 J CH GRM	a		b
FRONT	O	C	0902 87-012-195-080	C-CAP,U 100P-50 J CH GRM	a		b
FRONT	O	C	0903 87-012-195-080	C-CAP,U 100P-50 J CH GRM	a		b
FRONT	O	C	0904 87-012-195-080	C-CAP,U 100P-50 J CH GRM	a		b
FRONT	O	C	0905 87-012-195-080	C-CAP,U 100P-50 J CH GRM	a		b
FRONT	O	C	0906 87-012-195-080	C-CAP,U 100P-50 J CH GRM	a		b
FRONT	O	C	0907 87-012-195-080	C-CAP,U 100P-50 J CH GRM	a		b
FRONT	O	C	0908 87-012-195-080	C-CAP,U 100P-50 J CH GRM	a		b
FRONT	O	C	0909 87-012-195-080	C-CAP,U 100P-50 J CH GRM	a		b
FRONT	O	C	0910 87-012-195-080	C-CAP,U 100P-50 J CH GRM	a		b
FRONT	O	C	0911 87-012-274-080	C-CAP,U 1000P-50 K B GRM	a		b
FRONT	O	C	0912 87-010-759-080	C-CAP,U 0.1-25 Z F CM/CB	a		b
FRONT	O	C	0913 87-A10-189-040	CAP,E 220-10 M 5L	a		b
FRONT	O	C	0915 87-010-759-080	C-CAP,U 0.1-25 Z F CM/CB	a		b
FRONT	O	C	0916 87-010-759-080	C-CAP,U 0.1-25 Z F CM/CB	a		b
FRONT	O	C	0917 87-010-759-080	C-CAP,U 0.1-25 Z F CM/CB	a		b
FRONT	O	C	0919 87-012-286-080	C-CAP,U 0.01-25 K B GRM	a		b
FRONT	O	C	0920 87-010-829-080	C-CAP,U 0.047-16 Z F CM/CB	a		b
FRONT	O	C	0921 87-012-282-080	C-CAP,U 4700P-50 K B GRM	a		b
						EZSC1	KSC1
FRONT	O	C	0922 87-012-195-080	C-CAP,U 100P-50 J CH GRM	a		b
FRONT	O	C	0923 87-016-116-080	C-CAP,U 0.015-25 J B CB	a		b
FRONT	O	C	0924 87-016-116-080	C-CAP,U 0.015-25 J B CB	a		b
FRONT	O	C	0925 87-016-116-080	C-CAP,U 0.015-25 J B CB	a		b
FRONT	O	C	0931 87-012-195-080	C-CAP,U 100P-50 J CH GRM	a		b
FRONT	O	C	0932 87-012-195-080	C-CAP,U 100P-50 J CH GRM	a		b
FRONT	O	C	0951 87-012-172-080	C-CAP,U 10P-50 D CH GRM	a		b
FRONT	O	C	0952 87-010-854-080	C-CAP,S 560P-50 J CH CMC	a		b
FRONT	O	C	0953 87-012-349-080	C-CAP,S 1000P-50 J CH GRM	a		b
FRONT	O	C	0961 87-010-391-040	CAP,E 10-35 M 11L SME	a		b
FRONT	O	C	0962 87-012-336-080	C-CAP,U 330P-50 J SL GRM	a		b
FRONT	O	C	0963 87-010-759-080	C-CAP,U 0.1-25 Z F CM/CB	a		b
FRONT	O	CN	0103 87-099-013-010	CONN,11P V BLK 6216	a		b
FRONT	O	CN	0701 87-099-720-010	CONN,30P BLK TYK-B(P)	a		b
FRONT	O	CN	0731 87-099-196-010	CONN,8P V BLK 6216	a		b
FRONT	S	D	0103 87-020-465-080	DIODE,1SS133	a		b
FRONT	S	D	0104 87-020-465-080	DIODE,1SS133	a		b
FRONT	S	D	0301 87-A40-234-080	ZENER,MTZJ5.6A	a		b
FRONT	S	D	0302 87-020-465-080	DIODE,1SS133	a		b
FRONT	S	D	0601 87-A40-269-080	C-DIODE,MC2836	a		b
						EZSC1	KSC1
FRONT	S	D	0801 87-020-465-080	DIODE,1SS133	a		b
FRONT	S	D	0983 87-020-465-080	DIODE,1SS133	a		b
FRONT	O	FFC0103	88-911-101-110	FF-CABLE,11P 1.25 100MM	a		b
FRONT	O	FFC0731	88-908-291-110	FF-CABLE,8P 1.25 290MM	a		b
FRONT	O	FL	0201 8C-NF9-615-010	FL,HUA-13SS09T	a		b
FRONT	S	IC	0901 8C-NF9-611-030	C-IC,UPD780228GF-089-3BA	a		.
FRONT	S	IC	0901 8C-NF9-610-030	C-IC,UPD780226GF-033-3BA	.		b
FRONT	S	IC	0961 87-A21-831-010	IC,SPS-442-1-F1	.		b
FRONT	O	L	0951 87-A50-655-010	COIL,CLK 4.19MHZ (TOKO)7KLY	a		b
FRONT	O	LEDO201	87-A41-062-040	LED,LTL-1CHEE-012A RED	a		b
FRONT	S	Q	0102 87-A30-076-080	C-TR,2SC3052F	a		b
FRONT	S	Q	0104 87-A30-538-040	C-TR,SRA2202S	a		b
FRONT	S	Q	0301 87-A30-494-080	TR,2SA1980G	a		b
FRONT	S	Q	0302 87-A30-076-080	C-TR,2SC3052F	a		b
FRONT	S	Q	0303 87-A30-076-080	C-TR,2SC3052F	a		b
FRONT	S	Q	0601 87-A30-495-080	TR,2SA1981Y	a		b
FRONT	S	Q	0602 87-A30-495-080	TR,2SA1981Y	a		b
FRONT	S	Q	0603 87-A30-200-080	TR,2SA1585SR	a		b
FRONT	S	Q	0801 87-A30-076-080	C-TR,2SC3052F	a		b
FRONT	S	Q	0802 87-A30-075-080	C-TR,2SA1235F	a		b

ELECTRICAL PARTS LIST - 2/14

! = Δ SAFTY PARTS
 C = Components marked

All components used on this model at the production line are shown in this service manual.
 However, please note that not all components will be available as spare parts for after-sales service.
 Components marked S and O are designated as spare parts for service and will be stocked at the spare parts centers.
 Components marked X and R are not designated as spare parts for after sales service, and will not be stocked at the spare parts centers.

UNIT-NAME	! C	REF-NO	PARTS-NO	PARTS-NAME	SUFFIX&MODEL	CX-SNR21	CX-SNR20
					EZSC1	EZSC1	KSC1
FRONT	S	Q	0803	87-A30-076-080	C-TR,2SC3052F	a	b
FRONT	S	Q	0804	87-A30-076-080	C-TR,2SC3052F	a	b
FRONT	S	Q	0805	87-A30-076-080	C-TR,2SC3052F	a	b
FRONT	S	Q	0901	87-A30-538-040	C-TR,SRA2202S	a	b
FRONT	O	R	0109	88-108-224-080	C-RES,U 220K-1/16W J	a	b
FRONT	O	R	0110	88-108-153-080	C-RES,U 15K-1/16W J	a	b
FRONT	X	R	0111	88-108-333-080	C-RES,U 33K-1/16W J	a	b
FRONT	O	R	0112	88-108-224-080	C-RES,U 220K-1/16W J	a	b
FRONT	O	R	0114	88-108-103-080	C-RES,U 10K-1/16W J	a	b
FRONT	X	R	0115	88-108-000-080	C-JUMPER,U	a	b
FRONT	X	R	0116	88-108-124-080	C-RES,U 120K-1/16W J	a	b
FRONT	X	R	0151	88-100-000-010	PLATING-JW, 0.58 SN95	a	b
FRONT	X	R	0152	88-100-000-010	PLATING-JW, 0.58 SN95	a	b
FRONT	X	R	0153	88-128-821-080	C-RES, 820-1/8W J	a	b
FRONT	X	R	0154	88-128-821-080	C-RES, 820-1/8W J	a	b
FRONT	O	R	0155	88-108-332-080	C-RES,U 3.3K-1/16W J	a	b
FRONT	O	R	0156	88-108-332-080	C-RES,U 3.3K-1/16W J	a	b
FRONT	X	R	0161	88-108-000-080	C-JUMPER,U	a	b
FRONT	X	R	0162	88-108-000-080	C-JUMPER,U	a	b
FRONT	X	R	0163	88-108-000-080	C-JUMPER,U	a	b
					EZSC1	EZSC1	KSC1
FRONT	X	R	0164	88-108-000-080	C-JUMPER,U	a	b
FRONT	X	R	0165	88-108-000-080	C-JUMPER,U	a	b
FRONT	X	R	0166	88-108-000-080	C-JUMPER,U	a	b
FRONT	X	R	0208	88-128-102-080	C-RES, 1K-1/8W J	a	b
FRONT	X	R	0301	88-108-104-080	C-RES,U 100K-1/16W J	a	b
FRONT	X	R	0302	88-108-472-080	C-RES,U 4.7K-1/16W J	a	b
FRONT	O	R	0303	88-108-153-080	C-RES,U 15K-1/16W J	a	b
FRONT	O	R	0304	88-108-102-080	C-RES,U 1K-1/16W J	a	b
FRONT	X	R	0306	88-108-471-080	C-RES,U 470-1/16W J	a	b
FRONT	O	R	0321	88-108-103-080	C-RES,U 10K-1/16W J	a	b
FRONT	O	R	0322	88-108-102-080	C-RES,U 1K-1/16W J	a	b
FRONT	X	R	0323	88-108-821-080	C-RES,U 820-1/16W J	a	b
FRONT	O	R	0324	88-108-102-080	C-RES,U 1K-1/16W J	a	b
FRONT	X	R	0325	88-108-122-080	C-RES,U 1.2K-1/16W J	a	b
FRONT	X	R	0326	88-121-122-080	RES,1.2K-1/8W J	a	b
FRONT	X	R	0327	88-108-182-080	C-RES,U 1.8K-1/16W J	a	b
FRONT	X	R	0328	88-121-182-080	RES,1.8K-1/8W J	a	b
FRONT	O	R	0329	88-108-272-080	C-RES,U 2.7K-1/16W J	a	b
FRONT	O	R	0330	88-108-332-080	C-RES,U 3.3K-1/16W J	a	b
FRONT	X	R	0331	88-121-472-080	RES,4.7K-1/8W J	a	b
					EZSC1	EZSC1	KSC1
FRONT	X	R	0332	88-108-682-080	C-RES,U 6.8K-1/16W J	a	b
FRONT	O	R	0333	88-108-103-080	C-RES,U 10K-1/16W J	a	b
FRONT	X	R	0334	88-108-183-080	C-RES,U 18K-1/16W J	a	b
FRONT	O	R	0335	88-108-473-080	C-RES,U 47K-1/16W J	a	b
FRONT	O	R	0341	88-108-103-080	C-RES,U 10K-1/16W J	a	b
FRONT	O	R	0342	88-108-102-080	C-RES,U 1K-1/16W J	a	b
FRONT	X	R	0343	88-108-821-080	C-RES,U 820-1/16W J	a	b
FRONT	O	R	0344	88-108-102-080	C-RES,U 1K-1/16W J	a	b
FRONT	X	R	0345	88-108-122-080	C-RES,U 1.2K-1/16W J	a	b
FRONT	X	R	0346	88-108-122-080	C-RES,U 1.2K-1/16W J	a	b
FRONT	X	R	0347	88-108-182-080	C-RES,U 1.8K-1/16W J	a	b
FRONT	X	R	0348	88-108-182-080	C-RES,U 1.8K-1/16W J	a	b
FRONT	O	R	0349	88-108-272-080	C-RES,U 2.7K-1/16W J	a	.
FRONT	O	R	0350	88-108-332-080	C-RES,U 3.3K-1/16W J	a	.
FRONT	X	R	0351	88-108-472-080	C-RES,U 4.7K-1/16W J	a	.
FRONT	O	R	0361	88-108-103-080	C-RES,U 10K-1/16W J	a	b
FRONT	O	R	0362	88-108-103-080	C-RES,U 10K-1/16W J	a	b
FRONT	X	R	0363	88-108-100-080	C-RES,U 10-1/16W J	a	b
FRONT	X	R	0364	88-108-100-080	C-RES,U 10-1/16W J	a	b
FRONT	O	R	0371	88-108-103-080	C-RES,U 10K-1/16W J	a	b
					EZSC1	EZSC1	KSC1
FRONT	O	R	0372	88-108-103-080	C-RES,U 10K-1/16W J	a	b
FRONT	X	R	0373	88-108-100-080	C-RES,U 10-1/16W J	a	b
FRONT	X	R	0374	88-108-100-080	C-RES,U 10-1/16W J	a	b
FRONT	O	R	0601	88-108-103-080	C-RES,U 10K-1/16W J	a	b
FRONT	X	R	0602	88-108-222-080	C-RES,U 2.2K-1/16W J	a	b
FRONT	O	R	0603	88-108-103-080	C-RES,U 10K-1/16W J	a	b
FRONT	X	R	0604	88-108-222-080	C-RES,U 2.2K-1/16W J	a	b
FRONT	O	R	0605	88-108-103-080	C-RES,U 10K-1/16W J	a	b
FRONT	O	R	0606	88-108-102-080	C-RES,U 1K-1/16W J	a	b
FRONT	X	R	0607	88-108-000-080	C-JUMPER,U	a	b
FRONT	O	R	0611	88-108-473-080	C-RES,U 47K-1/16W J	a	b
FRONT	O	R	0612	88-108-473-080	C-RES,U 47K-1/16W J	a	b
FRONT	O	R	0613	88-108-473-080	C-RES,U 47K-1/16W J	a	b
FRONT	O	R	0614	88-108-473-080	C-RES,U 47K-1/16W J	a	b
FRONT	O	R	0615	88-108-473-080	C-RES,U 47K-1/16W J	a	b
FRONT	O	R	0617	88-108-473-080	C-RES,U 47K-1/16W J	a	b
FRONT	O	R	0618	88-108-473-080	C-RES,U 47K-1/16W J	a	b
FRONT	O	R	0701	88-108-102-080	C-RES,U 1K-1/16W J	a	.
FRONT	X	R	0702	88-128-102-080	C-RES, 1K-1/8W J	a	.
FRONT	O	R	0703	88-108-102-080	C-RES,U 1K-1/16W J	a	.

ELECTRICAL PARTS LIST - 3/14

! = Δ SAFTY PARTS
 C = Components marked

All components used on this model at the production line are shown in this service manual.
 However, please note that not all components will be available as spare parts for after-sales service.
 Components marked S and O are designated as spare parts for service and will be stocked at the spare parts centers.
 Components marked X and R are not designated as spare parts for after sales service, and will not be stocked at the spare parts centers.

UNIT-NAME	! C	REF-NO	PARTS-NO	PARTS-NAME	SUFFIX&MODEL	
					CX-SNR21	CX-SNR20
					EZSC1	KSC1
FRONT	O R	0704	88-108-102-080	C-RES,U 1K-1/16W J	a	b
FRONT	O R	0705	88-108-102-080	C-RES,U 1K-1/16W J	a	b
FRONT	O R	0706	88-108-102-080	C-RES,U 1K-1/16W J	a	b
FRONT	O R	0707	88-108-102-080	C-RES,U 1K-1/16W J	a	b
FRONT	X R	0708	88-121-102-080	RES,1K-1/8W J	a	b
FRONT	O R	0709	88-108-101-080	C-RES,U 100-1/16W J	a	b
FRONT	X R	0710	88-128-101-080	C-RES, 100-1/8W J	a	b
FRONT	O R	0711	88-108-101-080	C-RES,U 100-1/16W J	a	b
FRONT	O R	0712	88-108-101-080	C-RES,U 100-1/16W J	a	b
FRONT	X R	0719	88-108-100-080	C-RES,U 10-1/16W J	a	b
FRONT	O R	0721	88-108-103-080	C-RES,U 10K-1/16W J	a	b
FRONT	O R	0730	88-108-102-080	C-RES,U 1K-1/16W J	a	b
FRONT	O R	0732	88-108-101-080	C-RES,U 100-1/16W J	a	b
FRONT	O R	0733	88-108-101-080	C-RES,U 100-1/16W J	a	b
FRONT	O R	0734	88-108-102-080	C-RES,U 1K-1/16W J	a	b
FRONT	O R	0735	88-108-102-080	C-RES,U 1K-1/16W J	a	b
FRONT	O R	0740	88-108-102-080	C-RES,U 1K-1/16W J	a	b
FRONT	O R	0741	88-108-101-080	C-RES,U 100-1/16W J	a	b
FRONT	O R	0742	88-108-102-080	C-RES,U 1K-1/16W J	a	b
FRONT	X R	0743	88-108-474-080	C-RES,U 470K-1/16W J	a	b
					EZSC1	KSC1
FRONT	O R	0744	88-108-823-080	C-RES,U 82K-1/16W J	a	b
FRONT	X R	0745	88-108-104-080	C-RES,U 100K-1/16W J	a	b
FRONT	X R	0749	88-108-474-080	C-RES,U 470K-1/16W J	a	b
FRONT	O R	0803	88-108-102-080	C-RES,U 1K-1/16W J	a	b
FRONT	O R	0804	88-108-224-080	C-RES,U 220K-1/16W J	a	b
FRONT	X R	0805	88-108-273-080	C-RES,U 27K-1/16W J	a	b
FRONT	O R	0806	88-108-562-080	C-RES,U 5.6K-1/16W J	a	b
FRONT	X R	0807	88-108-000-080	C-JUMPER,U	a	b
FRONT	X R	0808	88-121-101-080	RES,100-1/8W J	a	b
FRONT	O R	0809	88-108-102-080	C-RES,U 1K-1/16W J	a	b
FRONT	X R	0810	88-108-182-080	C-RES,U 1.8K-1/16W J	a	b
FRONT	O R	0811	88-108-224-080	C-RES,U 220K-1/16W J	a	b
FRONT	O R	0813	88-108-224-080	C-RES,U 220K-1/16W J	a	b
FRONT	O R	0815	88-108-272-080	C-RES,U 2.7K-1/16W J	a	b
FRONT	X R	0816	88-108-104-080	C-RES,U 100K-1/16W J	a	b
FRONT	O R	0818	88-108-224-080	C-RES,U 220K-1/16W J	a	b
FRONT	X R	0819	88-108-222-080	C-RES,U 2.2K-1/16W J	a	b
FRONT	O R	0820	88-108-101-080	C-RES,U 100-1/16W J	a	b
FRONT	X R	0821	88-108-104-080	C-RES,U 100K-1/16W J	a	b
FRONT	O R	0822	88-108-224-080	C-RES,U 220K-1/16W J	a	b
					EZSC1	KSC1
FRONT	X R	0823	88-100-000-010	PLATING-JW, 0.58 SN95	a	b
FRONT	X R	0824	88-100-000-010	PLATING-JW, 0.58 SN95	a	b
FRONT	X R	0825	88-100-000-010	PLATING-JW, 0.58 SN95	a	b
FRONT	X R	0826	88-108-000-080	C-JUMPER,U	a	b
FRONT	O R	0827	88-108-473-080	C-RES,U 47K-1/16W J	a	b
FRONT	X R	0901	88-108-104-080	C-RES,U 100K-1/16W J	a	b
FRONT	X R	0902	88-108-104-080	C-RES,U 100K-1/16W J	a	b
FRONT	X R	0903	88-108-104-080	C-RES,U 100K-1/16W J	a	b
FRONT	X R	0904	88-108-104-080	C-RES,U 100K-1/16W J	a	b
FRONT	X R	0905	88-108-104-080	C-RES,U 100K-1/16W J	a	b
FRONT	X R	0906	88-108-104-080	C-RES,U 100K-1/16W J	a	b
FRONT	X R	0907	88-108-104-080	C-RES,U 100K-1/16W J	a	b
FRONT	X R	0908	88-108-104-080	C-RES,U 100K-1/16W J	a	b
FRONT	X R	0909	88-108-104-080	C-RES,U 100K-1/16W J	a	b
FRONT	X R	0910	88-108-104-080	C-RES,U 100K-1/16W J	a	b
FRONT	X R	0911	88-108-104-080	C-RES,U 100K-1/16W J	a	b
FRONT	X R	0912	88-108-104-080	C-RES,U 100K-1/16W J	a	b
FRONT	X R	0913	88-108-104-080	C-RES,U 100K-1/16W J	a	b
FRONT	X R	0914	88-108-104-080	C-RES,U 100K-1/16W J	a	b
FRONT	X R	0915	88-108-104-080	C-RES,U 100K-1/16W J	a	b
					EZSC1	KSC1
FRONT	X R	0916	88-108-104-080	C-RES,U 100K-1/16W J	a	b
FRONT	X R	0917	88-108-104-080	C-RES,U 100K-1/16W J	a	b
FRONT	X R	0918	88-108-104-080	C-RES,U 100K-1/16W J	a	b
FRONT	X R	0919	88-108-104-080	C-RES,U 100K-1/16W J	a	b
FRONT	X R	0920	88-108-104-080	C-RES,U 100K-1/16W J	a	b
FRONT	X R	0921	88-108-104-080	C-RES,U 100K-1/16W J	a	b
FRONT	X R	0922	88-108-104-080	C-RES,U 100K-1/16W J	a	b
FRONT	X R	0923	88-108-104-080	C-RES,U 100K-1/16W J	a	b
FRONT	X R	0924	88-108-104-080	C-RES,U 100K-1/16W J	a	b
FRONT	X R	0925	88-108-104-080	C-RES,U 100K-1/16W J	a	b
FRONT	X R	0926	88-108-104-080	C-RES,U 100K-1/16W J	a	b
FRONT	X R	0927	88-108-104-080	C-RES,U 100K-1/16W J	a	b
FRONT	X R	0928	88-108-104-080	C-RES,U 100K-1/16W J	a	b
FRONT	X R	0929	88-108-104-080	C-RES,U 100K-1/16W J	a	b
FRONT	X R	0930	88-108-104-080	C-RES,U 100K-1/16W J	a	b
FRONT	X R	0931	88-108-104-080	C-RES,U 100K-1/16W J	a	b
FRONT	X R	0932	88-108-104-080	C-RES,U 100K-1/16W J	a	b
FRONT	X R	0933	88-121-104-080	RES,100K-1/8W J	a	b
FRONT	X R	0934	88-108-683-080	C-RES,U 68K-1/16W J	a	b
FRONT	X R	0935	88-108-683-080	C-RES,U 68K-1/16W J	a	b

ELECTRICAL PARTS LIST - 4/14

! = Δ SAFTY PARTS
 C = Components marked

All components used on this model at the production line are shown in this service manual.
 However, please note that not all components will be available as spare parts for after-sales service.
 Components marked S and O are designated as spare parts for service and will be stocked at the spare parts centers.
 Components marked X and R are not designated as spare parts for after sales service, and will not be stocked at the spare parts centers.

UNIT-NAME	! C	REF-NO	PARTS-NO	PARTS-NAME	SUFFIX&MODEL	CX-SNR21	CX-SNR20
					EZSC1		KSC1
FRONT	X R	0936	88-108-104-080	C-RES,U 100K-1/16W J	a		b
FRONT	X R	0937	88-128-472-080	C-RES, 4.7K-1/8W J	a		b
FRONT	X R	0938	88-108-472-080	C-RES,U 4.7K-1/16W J	a		b
FRONT	X R	0939	88-108-472-080	C-RES,U 4.7K-1/16W J	a		b
FRONT	X R	0940	88-108-104-080	C-RES,U 100K-1/16W J	a		b
FRONT	X R	0941	88-108-104-080	C-RES,U 100K-1/16W J	a		b
FRONT	O R	0942	88-108-103-080	C-RES,U 10K-1/16W J	a		b
FRONT	X R	0943	88-121-472-080	RES,4.7K-1/8W J	a		b
FRONT	X R	0946	88-108-000-080	C-JUMPER,U	a		b
FRONT	X R	0947	88-108-104-080	C-RES,U 100K-1/16W J	a		b
FRONT	X R	0948	88-121-104-080	RES,100K-1/8W J	a		b
FRONT	O R	0951	88-108-102-080	C-RES,U 1K-1/16W J	a		b
FRONT	X R	0955	88-108-104-080	C-RES,U 100K-1/16W J	a		b
FRONT	X R	0956	88-108-104-080	C-RES,U 100K-1/16W J	a		b
FRONT	X R	0957	88-108-104-080	C-RES,U 100K-1/16W J	a		b
FRONT	O R	0958	88-108-103-080	C-RES,U 10K-1/16W J	a		b
FRONT	O R	0959	88-108-103-080	C-RES,U 10K-1/16W J	a		b
FRONT	X R	0961	88-121-181-080	RES,180-1/8W J	a		b
FRONT	O R	0963	88-108-563-080	C-RES,U 56K-1/16W J	a		b
FRONT	O R	0969	88-108-103-080	C-RES,U 10K-1/16W J	a		b
					EZSC1		KSC1
FRONT	O R	0981	88-108-103-080	C-RES,U 10K-1/16W J	a		b
FRONT	O R	0982	88-108-103-080	C-RES,U 10K-1/16W J	a		b
FRONT	O R	0983	88-108-103-080	C-RES,U 10K-1/16W J	a		b
FRONT	O R	0984	88-108-103-080	C-RES,U 10K-1/16W J	a		b
FRONT	X R	0985	88-121-103-080	RES,10K-1/8W J	a		b
FRONT	X R	0986	88-121-103-080	RES,10K-1/8W J	a		b
FRONT	O R	0987	88-108-103-080	C-RES,U 10K-1/16W J	a		b
FRONT	O R	0988	88-108-103-080	C-RES,U 10K-1/16W J	a		b
FRONT	O R	0989	88-108-103-080	C-RES,U 10K-1/16W J	a		b
FRONT	O S	0321	87-A90-164-080	SW,TACT SKQNAB (N)	a		b
FRONT	O S	0322	87-A90-164-080	SW,TACT SKQNAB (N)	a		b
FRONT	O S	0323	87-A90-164-080	SW,TACT SKQNAB (N)	a		b
FRONT	O S	0324	87-A90-164-080	SW,TACT SKQNAB (N)	a		b
FRONT	O S	0325	87-A90-164-080	SW,TACT SKQNAB (N)	a		b
FRONT	O S	0326	87-A90-164-080	SW,TACT SKQNAB (N)	a		b
FRONT	O S	0327	87-A90-164-080	SW,TACT SKQNAB (N)	a		b
FRONT	O S	0328	87-A90-164-080	SW,TACT SKQNAB (N)	a		b
FRONT	O S	0329	87-A90-164-080	SW,TACT SKQNAB (N)	a		b
FRONT	O S	0330	87-A90-164-080	SW,TACT SKQNAB (N)	a		b
FRONT	O S	0331	87-A90-164-080	SW,TACT SKQNAB (N)	a		b
					EZSC1		KSC1
FRONT	O S	0332	87-A90-164-080	SW,TACT SKQNAB (N)	a		b
FRONT	O S	0333	87-A90-164-080	SW,TACT SKQNAB (N)	a		b
FRONT	O S	0334	87-A90-164-080	SW,TACT SKQNAB (N)	a		b
FRONT	O S	0335	87-A90-164-080	SW,TACT SKQNAB (N)	a		b
FRONT	O S	0341	87-A90-164-080	SW,TACT SKQNAB (N)	a		b
FRONT	O S	0342	87-A90-164-080	SW,TACT SKQNAB (N)	a		b
FRONT	O S	0343	87-A90-164-080	SW,TACT SKQNAB (N)	a		b
FRONT	O S	0344	87-A90-164-080	SW,TACT SKQNAB (N)	a		b
FRONT	O S	0345	87-A90-164-080	SW,TACT SKQNAB (N)	a		b
FRONT	O S	0346	87-A90-164-080	SW,TACT SKQNAB (N)	a		b
FRONT	O S	0347	87-A90-164-080	SW,TACT SKQNAB (N)	a		b
FRONT	O S	0348	87-A90-164-080	SW,TACT SKQNAB (N)	a		b
FRONT	O S	0350	87-A90-164-080	SW,TACT SKQNAB (N)	a		.
FRONT	O S	0351	87-A90-164-080	SW,TACT SKQNAB (N)	a		.
FRONT	O S	0361	87-A92-370-010	SW,RTRY RE012307PVB30F	a		b
FRONT	O S	0371	87-A92-371-010	SW,RTRY RE0123PVB30F	a		b
HP	O C	0223	87-010-176-080	C-CAP,S 680P-50 J SL C2012	a		b
HP	O C	0224	87-010-176-080	C-CAP,S 680P-50 J SL C2012	a		b
HP	O J	0201	87-A60-420-010	JACK,3.5 ST (MSC)	a		b
HP	O R	0243	87-A00-440-050	RES,220-1/2W J RP	a		b
					EZSC1		KSC1
HP	O R	0244	87-A00-440-050	RES,220-1/2W J RP	a		b
HP	X R	0265	88-128-222-080	C-RES, 2.2K-1/8W J	a		b
HP	X R	0266	88-128-222-080	C-RES, 2.2K-1/8W J	a		b
HP	O WH	0201	87-A90-459-010	HLDR,WIRE 2.5-5P	a		b
MAIN	O C	0003	87-012-368-080	C-CAP,S 0.1-50 Z F GRM	a		b
MAIN	O C	0004	87-012-368-080	C-CAP,S 0.1-50 Z F GRM	a		b
MAIN	O C	0005	87-012-368-080	C-CAP,S 0.1-50 Z F GRM	a		b
MAIN	O C	0006	87-012-368-080	C-CAP,S 0.1-50 Z F GRM	a		b
MAIN	O C	0009	87-010-759-080	C-CAP,U 0.1-25 Z F CM/CB	a		b
MAIN	O C	0010	87-010-759-080	C-CAP,U 0.1-25 Z F CM/CB	a		b
MAIN	O C	0011	87-010-759-080	C-CAP,U 0.1-25 Z F CM/CB	a		b
MAIN	O C	0012	87-010-759-080	C-CAP,U 0.1-25 Z F CM/CB	a		b
MAIN	O C	0013	87-012-282-080	C-CAP,U 4700P-50 K B GRM	a		b
MAIN	O C	0014	87-010-260-080	CAP,E 47-25 M 11L SME	a		b
MAIN	O C	0016	87-012-286-080	C-CAP,U 0.01-25 K B GRM	a		b
MAIN	O C	0019	87-A12-432-000	CAP,E 3300-50 M 85 IV LELON	a		b
MAIN	O C	0020	87-A12-432-000	CAP,E 3300-50 M 85 IV LELON	a		b
MAIN	O C	0021	87-A12-755-000	CAP,E 4700-25 M 85 IV LELON	a		b
MAIN	O C	0022	87-A12-441-000	CAP,E 2200-35 M 85 IV LELON	a		b
MAIN	O C	0025	87-A12-079-080	CAP,E 100-35 SMG	a		b

ELECTRICAL PARTS LIST - 5/14

! = Δ SAFTY PARTS
 C = Components marked

All components used on this model at the production line are shown in this service manual.
 However, please note that not all components will be available as spare parts for after-sales service.
 Components marked S and O are designated as spare parts for service and will be stocked at the spare parts centers.
 Components marked X and R are not designated as spare parts for after sales service, and will not be stocked at the spare parts centers.

UNIT-NAME	! C	REF-NO	PARTS-NO	PARTS-NAME	SUFFIX&MODEL	CX-SNR21	CX-SNR20
						EZSC1	KSC1
MAIN	O	C	0026	87-010-393-080	CAP,E 100-35 M SME	a	b
MAIN	O	C	0027	87-010-393-080	CAP,E 100-35 M SME	a	b
MAIN	O	C	0028	87-010-393-080	CAP,E 100-35 M SME	a	b
MAIN	O	C	0030	87-010-247-080	CAP,E 100-50 M SME	a	b
MAIN	O	C	0031	87-010-263-080	CAP,E 100-10 M 11L SME	a	b
MAIN	O	C	0034	87-010-260-080	CAP,E 47-25 M 11L SME	a	b
MAIN	O	C	0035	87-010-405-080	CAP,E 10-50 M 11L SME	a	b
MAIN	O	C	0036	87-010-260-080	CAP,E 47-25 M 11L SME	a	b
MAIN	O	C	0060	87-010-403-080	CAP,E 3.3-50 M 11L SME	a	b
MAIN	O	C	0061	87-010-260-080	CAP,E 47-25 M 11L SME	a	b
MAIN	O	C	0083	87-010-235-080	CAP,E 470-16 M SME	a	b
MAIN	O	C	0097	87-010-759-080	C-CAP,U 0.1-25 Z F CM/CB	a	b
MAIN	O	C	0101	87-012-279-080	C-CAP,U 2700P-50 K B GRM	a	b
MAIN	O	C	0102	87-012-279-080	C-CAP,U 2700P-50 K B GRM	a	b
MAIN	O	C	0103	87-010-544-080	CAP,E 0.1-50 M 11L SME	a	b
MAIN	O	C	0104	87-010-544-080	CAP,E 0.1-50 M 11L SME	a	b
MAIN	O	C	0107	87-010-404-080	CAP,E 4.7-50 M 11L SME	a	b
MAIN	O	C	0108	87-010-404-080	CAP,E 4.7-50 M 11L SME	a	b
MAIN	O	C	0109	87-012-195-080	C-CAP,U 100P-50 J CH GRM	a	b
MAIN	O	C	0110	87-012-195-080	C-CAP,U 100P-50 J CH GRM	a	b
						EZSC1	KSC1
MAIN	O	C	0111	87-010-407-080	CAP,E 33-50 M 11L SME	a	b
MAIN	O	C	0112	87-010-407-080	CAP,E 33-50 M 11L SME	a	b
MAIN	O	C	0113	87-012-195-080	C-CAP,U 100P-50 J CH GRM	a	b
MAIN	O	C	0114	87-012-195-080	C-CAP,U 100P-50 J CH GRM	a	b
MAIN	O	C	0117	87-012-368-080	C-CAP,S 0.1-50 Z F GRM	a	b
MAIN	O	C	0118	87-012-368-080	C-CAP,S 0.1-50 Z F GRM	a	b
MAIN	O	C	0119	87-012-286-080	C-CAP,U 0.01-25 K B GRM	a	b
MAIN	O	C	0120	87-012-286-080	C-CAP,U 0.01-25 K B GRM	a	b
MAIN	O	C	0121	87-010-401-080	CAP,E 1-50 M 11L SME	a	b
MAIN	O	C	0122	87-010-401-080	CAP,E 1-50 M 11L SME	a	b
MAIN	O	C	0123	87-010-177-080	C-CAP,S 820P-50 J SL C2012	a	b
MAIN	O	C	0124	87-010-177-080	C-CAP,S 820P-50 J SL C2012	a	b
MAIN	O	C	0125	87-012-195-080	C-CAP,U 100P-50 J CH GRM	a	b
MAIN	O	C	0126	87-012-195-080	C-CAP,U 100P-50 J CH GRM	a	b
MAIN	O	C	0133	87-012-282-080	C-CAP,U 4700P-50 K B GRM	a	b
MAIN	O	C	0140	87-012-278-080	C-CAP,U 2200P-50 K B GRM	a	b
MAIN	O	C	0145	87-012-282-080	C-CAP,U 4700P-50 K B GRM	a	b
MAIN	O	C	0146	87-012-282-080	C-CAP,U 4700P-50 K B GRM	a	b
MAIN	O	C	0186	87-010-759-080	C-CAP,U 0.1-25 Z F CM/CB	a	b
MAIN	O	C	0187	87-010-866-080	CAP,E 10-63 M VX	a	b
						EZSC1	KSC1
MAIN	O	C	0188	87-010-866-080	CAP,E 10-63 M VX	a	b
MAIN	O	C	0201	87-A10-260-080	C-CAP,U 0.1-16 K B	a	b
MAIN	O	C	0225	87-012-368-080	C-CAP,S 0.1-50 Z F GRM	a	b
MAIN	O	C	0226	87-012-368-080	C-CAP,S 0.1-50 Z F GRM	a	b
MAIN	O	C	0227	87-012-368-080	C-CAP,S 0.1-50 Z F GRM	a	b
MAIN	O	C	0228	87-012-368-080	C-CAP,S 0.1-50 Z F GRM	a	b
MAIN	O	C	0229	87-010-191-080	C-CAP,S 0.015-50 Z F GRM	a	b
MAIN	O	C	0230	87-010-191-080	C-CAP,S 0.015-50 Z F GRM	a	b
MAIN	O	C	0231	87-012-286-080	C-CAP,U 0.01-25 K B GRM	a	b
MAIN	O	C	0232	87-012-286-080	C-CAP,U 0.01-25 K B GRM	a	b
MAIN	O	C	0241	87-010-759-080	C-CAP,U 0.1-25 Z F CM/CB	a	b
MAIN	O	C	0301	87-012-275-080	C-CAP,U 1200P-50 K B GRM	a	b
MAIN	O	C	0302	87-012-275-080	C-CAP,U 1200P-50 K B GRM	a	b
MAIN	O	C	0303	87-012-275-080	C-CAP,U 1200P-50 K B GRM	a	b
MAIN	O	C	0304	87-012-275-080	C-CAP,U 1200P-50 K B GRM	a	b
MAIN	O	C	0305	87-A10-039-080	C-CAP,U 470P-50 J CH	a	b
MAIN	O	C	0310	87-012-274-080	C-CAP,U 1000P-50 K B GRM	a	b
MAIN	O	C	0363	87-010-759-080	C-CAP,U 0.1-25 Z F CM/CB	a	b
MAIN	O	C	0451	87-010-759-080	C-CAP,U 0.1-25 Z F CM/CB	a	b
MAIN	O	C	0452	87-010-406-080	CAP,E 22-50 M 11L SME	a	b
						EZSC1	KSC1
MAIN	O	C	0453	87-012-279-080	C-CAP,U 2700P-50 K B GRM	a	b
MAIN	O	C	0454	87-012-279-080	C-CAP,U 2700P-50 K B GRM	a	b
MAIN	O	C	0455	87-012-279-080	C-CAP,U 2700P-50 K B GRM	a	b
MAIN	O	C	0456	87-012-286-080	C-CAP,U 0.01-25 K B GRM	a	b
MAIN	O	C	0457	87-A12-361-080	CAP,M 5600P-100 J CP	a	b
MAIN	O	C	0458	87-012-278-080	C-CAP,U 2200P-50 K B GRM	a	b
MAIN	O	C	0459	87-012-271-080	C-CAP,U 560P-50 K B GRM	a	b
MAIN	O	C	0460	87-012-368-080	C-CAP,S 0.1-50 Z F GRM	a	b
MAIN	O	C	0461	87-012-158-080	C-CAP,S 390P-50 J CH GRM	a	b
MAIN	O	C	0462	87-012-158-080	C-CAP,S 390P-50 J CH GRM	a	b
MAIN	O	C	0463	87-010-759-080	C-CAP,U 0.1-25 Z F CM/CB	a	b
MAIN	O	C	0464	87-012-278-080	C-CAP,U 2200P-50 K B GRM	a	b
MAIN	O	C	0465	87-012-286-080	C-CAP,U 0.01-25 K B GRM	a	b
MAIN	O	C	0601	87-012-188-080	C-CAP,U 47P-50 J CH GRM	a	b
MAIN	O	C	0602	87-012-188-080	C-CAP,U 47P-50 J CH GRM	a	b
MAIN	O	C	0603	87-010-263-080	CAP,E 100-10 M 11L SME	a	b
MAIN	O	C	0604	87-010-263-080	CAP,E 100-10 M 11L SME	a	b
MAIN	O	C	0605	87-A12-362-080	CAP,M 6800P-100 J CP	a	b
MAIN	O	C	0606	87-A12-362-080	CAP,M 6800P-100 J CP	a	b
MAIN	O	C	0607	87-A10-039-080	C-CAP,U 470P-50 J CH	a	b

ELECTRICAL PARTS LIST - 6/14

! = Δ SAFTY PARTS
 C = Components marked

All components used on this model at the production line are shown in this service manual.
 However, please note that not all components will be available as spare parts for after-sales service.
 Components marked S and O are designated as spare parts for service and will be stocked at the spare parts centers.
 Components marked X and R are not designated as spare parts for after sales service, and will not be stocked at the spare parts centers.

UNIT-NAME	! C	REF-NO	PARTS-NO	PARTS-NAME	SUFFIX&MODEL	CX-SNR21	CX-SNR20
					EZSC1	EZSC1	KSC1
MAIN	O	C	0608	87-A10-039-080	C-CAP,U 470P-50 J CH	a	b
MAIN	O	C	0609	87-010-401-080	CAP,E 1-50 M 11L SME	a	b
MAIN	O	C	0610	87-010-401-080	CAP,E 1-50 M 11L SME	a	b
MAIN	O	C	0611	87-A12-348-080	C-CAP,U 560P-25 J CH	a	b
MAIN	O	C	0612	87-A12-348-080	C-CAP,U 560P-25 J CH	a	b
MAIN	O	C	0613	87-012-280-080	C-CAP,U 3300P-50 K B GRM	a	b
MAIN	O	C	0614	87-012-280-080	C-CAP,U 3300P-50 K B GRM	a	b
MAIN	O	C	0615	87-010-545-080	CAP,E 0.22-50 M 11L SME	a	b
MAIN	O	C	0616	87-010-545-080	CAP,E 0.22-50 M 11L SME	a	b
MAIN	O	C	0617	87-010-545-080	CAP,E 0.22-50 M 11L SME	a	b
MAIN	O	C	0618	87-010-545-080	CAP,E 0.22-50 M 11L SME	a	b
MAIN	O	C	0625	87-012-198-080	C-CAP,U 180P-50 J CH GRM	a	b
MAIN	O	C	0626	87-012-198-080	C-CAP,U 180P-50 J CH GRM	a	b
MAIN	O	C	0627	87-012-284-080	C-CAP,U 6800P-50 K B GRM	a	b
MAIN	O	C	0628	87-012-284-080	C-CAP,U 6800P-50 K B GRM	a	b
MAIN	O	C	0629	87-012-286-080	C-CAP,U 0.01-25 K B GRM	a	b
MAIN	O	C	0630	87-012-286-080	C-CAP,U 0.01-25 K B GRM	a	b
MAIN	O	C	0631	87-012-278-080	C-CAP,U 2200P-50 K B GRM	a	b
MAIN	O	C	0632	87-012-278-080	C-CAP,U 2200P-50 K B GRM	a	b
MAIN	O	C	0641	87-010-401-080	CAP,E 1-50 M 11L SME	a	b
					EZSC1	EZSC1	KSC1
MAIN	O	C	0642	87-010-401-080	CAP,E 1-50 M 11L SME	a	b
MAIN	O	C	0651	87-010-248-080	CAP,E 220-10 M 11L SME	a	b
MAIN	O	C	0652	87-010-260-080	CAP,E 47-25 M 11L SME	a	b
MAIN	O	C	0655	87-010-404-080	CAP,E 4.7-50 M 11L SME	a	b
MAIN	O	C	0656	87-010-784-080	C-CAP,U 0.012-25 K B GRM	a	b
MAIN	O	C	0663	87-010-759-080	C-CAP,U 0.1-25 Z F CM/CB	a	b
MAIN	O	C	0664	87-010-759-080	C-CAP,U 0.1-25 Z F CM/CB	a	b
MAIN	O	C	0665	87-A10-504-080	C-CAP,U 0.047-16 K B	a	b
MAIN	O	C	0666	87-A10-504-080	C-CAP,U 0.047-16 K B	a	b
MAIN	O	C	0677	87-012-286-080	C-CAP,U 0.01-25 K B GRM	a	b
MAIN	O	C	0771	87-010-263-080	CAP,E 100-10 M 11L SME	a	b
MAIN	O	C	0772	87-012-286-080	C-CAP,U 0.01-25 K B GRM	a	b
MAIN	X	C	0781	88-108-000-080	C-JUMPER,U	a	b
MAIN	O	C	0782	87-012-286-080	C-CAP,U 0.01-25 K B GRM	a	b
MAIN	O	C	0783	87-012-286-080	C-CAP,U 0.01-25 K B GRM	a	b
MAIN	O	C	0784	87-012-286-080	C-CAP,U 0.01-25 K B GRM	a	b
MAIN	O	C	0785	87-012-286-080	C-CAP,U 0.01-25 K B GRM	a	b
MAIN	O	C	0786	87-012-286-080	C-CAP,U 0.01-25 K B GRM	a	b
MAIN	O	C	0788	87-012-167-080	C-CAP,U 5P-50 C CH GRM	a	b
MAIN	O	C	0789	87-016-118-080	C-CAP,U 0.022-25 J B GRM	a	b
					EZSC1	EZSC1	KSC1
MAIN	O	C	0790	87-016-118-080	C-CAP,U 0.022-25 J B GRM	a	b
MAIN	O	C	0791	87-010-759-080	C-CAP,U 0.1-25 Z F CM/CB	a	b
MAIN	O	C	0792	87-012-286-080	C-CAP,U 0.01-25 K B GRM	a	b
MAIN	O	C	0793	87-010-404-080	CAP,E 4.7-50 M 11L SME	a	b
MAIN	O	C	0795	87-012-286-080	C-CAP,U 0.01-25 K B GRM	a	b
MAIN	O	C	0796	87-012-286-080	C-CAP,U 0.01-25 K B GRM	a	b
MAIN	O	C	0797	87-010-405-080	CAP,E 10-50 M 11L SME	a	b
MAIN	O	C	0798	87-012-286-080	C-CAP,U 0.01-25 K B GRM	a	b
MAIN	O	C	0799	87-010-265-080	CAP,E 33-16 M 11L SME	a	b
MAIN	O	C	0800	87-010-829-080	C-CAP,U 0.047-16 Z F CM/CB	a	b
MAIN	O	C	0801	87-010-403-080	CAP,E 3.3-50 M 11L SME	a	b
MAIN	O	C	0802	87-010-829-080	C-CAP,U 0.047-16 Z F CM/CB	a	b
MAIN	O	C	0803	87-010-787-080	C-CAP,U 0.022-25 K B GRM	a	b
MAIN	O	C	0804	87-010-263-080	CAP,E 100-10 M 11L SME	a	b
MAIN	O	C	0807	87-010-400-080	CAP,E 0.47-50 M 11L SME	a	b
MAIN	O	C	0808	87-010-401-080	CAP,E 1-50 M 11L SME	a	b
MAIN	O	C	0809	87-010-401-080	CAP,E 1-50 M 11L SME	a	b
MAIN	O	C	0810	87-010-759-080	C-CAP,U 0.1-25 Z F CM/CB	a	b
MAIN	O	C	0814	87-012-286-080	C-CAP,U 0.01-25 K B GRM	a	b
MAIN	O	C	0815	87-010-400-080	CAP,E 0.47-50 M 11L SME	a	b
					EZSC1	EZSC1	KSC1
MAIN	O	C	0816	87-010-400-080	CAP,E 0.47-50 M 11L SME	a	b
MAIN	O	C	0818	87-012-276-080	C-CAP,U 1500P-50 K B GRM	a	b
MAIN	O	C	0821	87-010-405-080	CAP,E 10-50 M 11L SME	a	b
MAIN	X	C	0822	88-108-000-080	C-JUMPER,U	a	b
MAIN	O	C	0823	87-012-349-080	C-CAP,S 1000P-50 J CH GRM	a	b
MAIN	O	C	0824	87-010-404-080	CAP,E 4.7-50 M 11L SME	a	b
MAIN	O	C	0825	87-010-596-080	C-CAP,S 0.047-16 K R C2012	a	b
MAIN	O	C	0831	87-010-406-080	CAP,E 22-50 M 11L SME	a	b
MAIN	O	C	0842	87-012-286-080	C-CAP,U 0.01-25 K B GRM	a	b
MAIN	X	C	0843	88-108-000-080	C-JUMPER,U	a	b
MAIN	O	C	0844	87-012-286-080	C-CAP,U 0.01-25 K B GRM	a	b
MAIN	X	C	0845	88-108-000-080	C-JUMPER,U	a	b
MAIN	X	C	0846	88-108-000-080	C-JUMPER,U	a	b
MAIN	X	C	0847	88-108-000-080	C-JUMPER,U	a	b
MAIN	X	C	0848	88-108-000-080	C-JUMPER,U	a	b
MAIN	X	C	0849	88-108-000-080	C-JUMPER,U	a	b
MAIN	O	C	0850	87-010-260-080	CAP,E 47-25 M 11L SME	a	b
MAIN	O	C	0851	87-012-286-080	C-CAP,U 0.01-25 K B GRM	a	b
MAIN	O	C	0852	87-012-286-080	C-CAP,U 0.01-25 K B GRM	a	b
MAIN	O	C	0853	87-012-286-080	C-CAP,U 0.01-25 K B GRM	a	b

ELECTRICAL PARTS LIST - 7/14

! = Δ SAFTY PARTS
 C = Components marked

All components used on this model at the production line are shown in this service manual.
 However, please note that not all components will be available as spare parts for after-sales service.
 Components marked S and O are designated as spare parts for service and will be stocked at the spare parts centers.
 Components marked X and R are not designated as spare parts for after sales service, and will not be stocked at the spare parts centers.

UNIT-NAME	! C	REF-NO	PARTS-NO	PARTS-NAME	SUFFIX&MODEL	CX-SNR21	CX-SNR20
						EZSC1	KSC1
MAIN	O C	0859	87-010-759-080	C-CAP,U 0.1-25 Z F CM/CB	a		b
MAIN	O C	0860	87-012-286-080	C-CAP,U 0.01-25 K B GRM	a		b
MAIN	O C	0869	87-012-286-080	C-CAP,U 0.01-25 K B GRM	a		.
MAIN	O C	0870	87-012-274-080	C-CAP,U 1000P-50 K B GRM	a		.
MAIN	O C	0871	87-012-199-080	C-CAP,U 220P-50 J CH GRM	a		.
MAIN	O C	0872	87-012-199-080	C-CAP,U 220P-50 J CH GRM	a		.
MAIN	O C	0873	87-A10-039-080	C-CAP,U 470P-50 J CH	a		.
MAIN	O C	0874	87-010-405-080	CAP,E 10-50 M 11L SME	a		.
MAIN	O C	0875	87-010-759-080	C-CAP,U 0.1-25 Z F CM/CB	a		.
MAIN	O C	0876	87-010-405-080	CAP,E 10-50 M 11L SME	a		.
MAIN	O C	0877	87-012-286-080	C-CAP,U 0.01-25 K B GRM	a		.
MAIN	O C	0878	87-012-184-080	C-CAP,U 33P-50 J CH GRM	a		.
MAIN	O C	0879	87-012-180-080	C-CAP,U 22P-50 J CH GRM	a		.
MAIN	O C	0901	87-012-162-080	C-CAP,U 1P-50 C CH GRM	a		b
MAIN	O C	0902	87-012-165-080	C-CAP,U 3P-50 C CH GRM	a		b
MAIN	O C	0903	87-012-164-080	C-CAP,U 2P-50 C CH GRM	a		b
MAIN	O C	0904	86-ZA1-615-080	C-CAP,U 680P-25 J CH	a		b
MAIN	O C	0905	87-012-162-080	C-CAP,U 1P-50 C CH GRM	a		b
MAIN	O C	0906	87-012-172-080	C-CAP,U 10P-50 D CH GRM	a		b
MAIN	O C	0907	87-012-166-080	C-CAP,U 4P-50 C CH GRM	a		b
						EZSC1	KSC1
MAIN	O C	0908	87-012-165-080	C-CAP,U 3P-50 C CH GRM	a		b
MAIN	O C	0909	86-ZA1-615-080	C-CAP,U 680P-25 J CH	a		b
MAIN	O C	0910	87-012-164-080	C-CAP,U 2P-50 C CH GRM	a		b
MAIN	O C	0911	87-012-166-080	C-CAP,U 4P-50 C CH GRM	a		b
MAIN	O C	0912	87-012-195-080	C-CAP,U 100P-50 J CH GRM	a		b
MAIN	O C	0913	86-ZA1-616-080	C-CAP,U 0.01-50 K B (MUR)	a		b
MAIN	O C	0914	86-ZA1-616-080	C-CAP,U 0.01-50 K B (MUR)	a		b
MAIN	O C	0915	86-ZA1-616-080	C-CAP,U 0.01-50 K B (MUR)	a		b
MAIN	O C	0916	86-ZA1-616-080	C-CAP,U 0.01-50 K B (MUR)	a		b
MAIN	O C	0917	87-012-178-080	C-CAP,U 18P-50 J CH GRM	a		b
MAIN	O C	0918	87-012-172-080	C-CAP,U 10P-50 D CH GRM	a		b
MAIN	O C	0919	87-012-184-080	C-CAP,U 33P-50 J CH GRM	a		b
MAIN	O C	0920	87-012-184-080	C-CAP,U 33P-50 J CH GRM	a		b
MAIN	O C	0921	87-012-180-080	C-CAP,U 22P-50 J CH GRM	a		b
MAIN	O C	0922	87-012-174-080	C-CAP,U 12P-50 J CH GRM	a		b
MAIN	O C	0923	86-ZA1-616-080	C-CAP,U 0.01-50 K B (MUR)	a		b
MAIN	O C	0924	87-012-164-080	C-CAP,U 2P-50 C CH GRM	a		b
MAIN	O C	0925	87-012-164-080	C-CAP,U 2P-50 C CH GRM	a		b
MAIN	O C	0926	86-ZA1-616-080	C-CAP,U 0.01-50 K B (MUR)	a		b
MAIN	O C	0931	87-A12-319-080	C-CAP,U 0.1-25 K B	a		b
						EZSC1	KSC1
MAIN	O C	0940	87-012-286-080	C-CAP,U 0.01-25 K B GRM	a		b
MAIN	O C	0942	87-012-167-080	C-CAP,U 5P-50 C CH GRM	a		b
MAIN	O C	0947	87-012-286-080	C-CAP,U 0.01-25 K B GRM	a		b
MAIN	O C	0948	87-A10-039-080	C-CAP,U 470P-50 J CH	a		b
MAIN	O C	0952	87-012-286-080	C-CAP,U 0.01-25 K B GRM	a		b
MAIN	O C	0958	87-012-286-080	C-CAP,U 0.01-25 K B GRM	a		b
MAIN	O C	0959	87-010-759-080	C-CAP,U 0.1-25 Z F CM/CB	a		b
MAIN	O C	0960	87-010-759-080	C-CAP,U 0.1-25 Z F CM/CB	a		b
MAIN	O C	0962	87-010-401-080	CAP,E 1-50 M 11L SME	a		b
MAIN	O C	0963	87-A12-319-080	C-CAP,U 0.1-25 K B	a		b
MAIN	O C	0971	87-010-381-080	CAP,E 330-16 M SME	a		b
MAIN	O C	0972	87-010-404-080	CAP,E 4.7-50 M 11L SME	a		b
MAIN	O C	0973	87-012-286-080	C-CAP,U 0.01-25 K B GRM	a		b
MAIN	O C	0974	87-012-286-080	C-CAP,U 0.01-25 K B GRM	a		b
MAIN	O C	0979	87-012-195-080	C-CAP,U 100P-50 J CH GRM	a		b
MAIN	O C	0981	87-010-260-080	CAP,E 47-25 M 11L SME	a		b
MAIN	O C	0982	87-010-759-080	C-CAP,U 0.1-25 Z F CM/CB	a		b
MAIN	O C	0983	87-012-286-080	C-CAP,U 0.01-25 K B GRM	a		b
MAIN	O C	0984	87-012-286-080	C-CAP,U 0.01-25 K B GRM	a		b
MAIN	O C	0985	87-012-195-080	C-CAP,U 100P-50 J CH GRM	a		b
						EZSC1	KSC1
MAIN	O C	0987	87-012-286-080	C-CAP,U 0.01-25 K B GRM	a		b
MAIN	O C	0988	87-012-286-080	C-CAP,U 0.01-25 K B GRM	a		b
MAIN	O C	0989	87-012-286-080	C-CAP,U 0.01-25 K B GRM	a		b
MAIN	O C	0991	87-012-176-080	C-CAP,U 15P-50 J CH GRM	a		b
MAIN	O C	0992	87-012-176-080	C-CAP,U 15P-50 J CH GRM	a		b
MAIN	O C	0993	87-012-274-080	C-CAP,U 1000P-50 K B GRM	a		b
MAIN	O C	0995	87-012-274-080	C-CAP,U 1000P-50 K B GRM	a		b
MAIN	O C	0997	87-010-759-080	C-CAP,U 0.1-25 Z F CM/CB	a		b
MAIN	O C	0998	87-010-260-080	CAP,E 47-25 M 11L SME	a		b
MAIN	O C	0999	87-A11-155-080	CAP,TC U 0.01-16 Z F	a		b
MAIN	O CF	0831	87-008-423-010	FLTR,CF SFE10.7MS3G-A	a		b
MAIN	O CF	0832	82-785-747-010	CF,MS2GH-A	a		b
MAIN	X	CLP0303	87-A60-884-010	PIN,DIA1 COATING-SHS	a		b
MAIN	X	CLP0304	87-A60-884-010	PIN,DIA1 COATING-SHS	a		b
MAIN	O CN	0301	87-A60-620-010	CONN,3P V 2MM JMT	a		b
MAIN	O CN	0302	87-A60-625-010	CONN,8P V 2MM JMT	a		b
MAIN	O CN	0601	87-099-719-010	CONN,30P H BLK TYK-B(X)	a		b
MAIN	O CN	0602	87-099-194-010	CONN,6P V BLK 6216	a		b
MAIN	O	CNA0301	8C-NF9-605-010	CONN ASSY,3P -PB	a		b
MAIN	O	CNA0302	8C-NF9-606-010	CONN ASSY,8P -RPB	a		b

ELECTRICAL PARTS LIST - 8/14

! = Δ SAFTY PARTS
 C = Components marked

All components used on this model at the production line are shown in this service manual.
 However, please note that not all components will be available as spare parts for after-sales service.
 Components marked S and O are designated as spare parts for service and will be stocked at the spare parts centers.
 Components marked X and R are not designated as spare parts for after sales service, and will not be stocked at the spare parts centers.

UNIT-NAME	!	C	REF-NO	PARTS-NO	PARTS-NAME	SUFFIX&MODEL		
						CX-SNR21	CX-SNR20	
						EZSC1	KSC1	
MAIN		S	D	0011	87-A40-270-080	C-DIODE,MC2838	a	b
MAIN		S	D	0013	87-A40-459-090	DIODE,RL203GW (15MM)	a	b
MAIN		S	D	0014	87-A40-459-090	DIODE,RL203GW (15MM)	a	b
MAIN		S	D	0015	87-A40-459-090	DIODE,RL203GW (15MM)	a	b
MAIN		S	D	0016	87-A40-459-090	DIODE,RL203GW (15MM)	a	b
MAIN		S	D	0017	87-A40-459-090	DIODE,RL203GW (15MM)	a	b
MAIN		S	D	0018	87-A40-459-090	DIODE,RL203GW (15MM)	a	b
MAIN		S	D	0019	87-A40-459-090	DIODE,RL203GW (15MM)	a	b
MAIN		S	D	0020	87-A40-459-090	DIODE,RL203GW (15MM)	a	b
MAIN		S	D	0021	87-A40-345-080	ZENER,MTZJ10C	a	b
MAIN		S	D	0025	87-A40-553-080	DIODE,1N4003 LES	a	b
MAIN		S	D	0026	87-A40-553-080	DIODE,1N4003 LES	a	b
MAIN		S	D	0027	87-A40-553-080	DIODE,1N4003 LES	a	b
MAIN		S	D	0028	87-A40-553-080	DIODE,1N4003 LES	a	b
MAIN		S	D	0029	87-A40-336-080	ZENER,MTZJ27D T-72	a	b
MAIN		S	D	0030	87-020-465-080	DIODE,1SS133	a	b
MAIN		S	D	0032	87-020-465-080	DIODE,1SS133	a	b
MAIN		S	D	0041	87-A40-270-080	C-DIODE,MC2838	a	b
MAIN		S	D	0042	87-A40-269-080	C-DIODE,MC2836	a	b
MAIN		S	D	0060	87-020-465-080	DIODE,1SS133	a	b
						EZSC1	KSC1	
MAIN		S	D	0063	87-A40-270-080	C-DIODE,MC2838	a	b
MAIN		S	D	0064	87-A40-269-080	C-DIODE,MC2836	a	b
MAIN		S	D	0076	87-A40-269-080	C-DIODE,MC2836	a	b
MAIN		S	D	0077	87-A40-270-080	C-DIODE,MC2838	a	b
MAIN		S	D	0101	87-A40-269-080	C-DIODE,MC2836	a	b
MAIN		S	D	0103	87-020-465-080	DIODE,1SS133	a	b
MAIN		S	D	0104	87-020-465-080	DIODE,1SS133	a	b
MAIN		S	D	0105	87-A40-269-080	C-DIODE,MC2836	a	b
MAIN		S	D	0106	87-A40-269-080	C-DIODE,MC2836	a	b
MAIN		S	D	0107	87-A40-270-080	C-DIODE,MC2838	a	b
MAIN		S	D	0108	87-A40-270-080	C-DIODE,MC2838	a	b
MAIN		S	D	0109	87-A40-488-080	DIODE,1SS244	a	b
MAIN		S	D	0110	87-A40-488-080	DIODE,1SS244	a	b
MAIN		S	D	0160	87-A40-270-080	C-DIODE,MC2838	a	b
MAIN		S	D	0161	87-A40-459-090	DIODE,RL203GW (15MM)	a	b
MAIN		S	D	0162	87-A40-459-090	DIODE,RL203GW (15MM)	a	b
MAIN		S	D	0187	87-A40-871-080	ZENER,MTZJ5.6C	a	b
MAIN		S	D	0188	87-017-931-080	ZENER,MTZJ5.6B	a	b
MAIN		S	D	0189	87-A40-270-080	C-DIODE,MC2838	a	b
MAIN		S	D	0190	87-A40-269-080	C-DIODE,MC2836	a	b
						EZSC1	KSC1	
MAIN		S	D	0191	87-A40-345-080	ZENER,MTZJ10C	a	b
MAIN		S	D	0192	87-020-465-080	DIODE,1SS133	a	b
MAIN		S	D	0193	87-020-465-080	DIODE,1SS133	a	b
MAIN		S	D	0280	87-A40-269-080	C-DIODE,MC2836	a	b
MAIN		S	D	0281	87-A40-270-080	C-DIODE,MC2838	a	b
MAIN		S	D	0301	87-A40-269-080	C-DIODE,MC2836	a	b
MAIN		S	D	0661	87-A40-438-080	ZENER,MTZJ4.7A	a	b
MAIN		S	D	0662	87-A40-438-080	ZENER,MTZJ4.7A	a	b
MAIN		S	D	0801	87-020-465-080	DIODE,1SS133	a	b
MAIN		S	D	0803	87-020-465-080	DIODE,1SS133	a	b
MAIN		O	D	0901	87-A41-048-040	C-VARI-CAP,HVM16-03 TL	a	b
MAIN		O	D	0902	87-A41-048-040	C-VARI-CAP,HVM16-03 TL	a	b
MAIN		O	D	0903	87-A41-048-040	C-VARI-CAP,HVM16-03 TL	a	b
MAIN		S	D	0942	87-A40-270-080	C-DIODE,MC2838	a	b
MAIN		S	D	0944	87-020-465-080	DIODE,1SS133	a	b
MAIN		O	D	0951	87-A40-799-040	C-VARI-CAP,KV1610S	a	b
MAIN		S	D	0991	87-017-149-080	ZENER,HZS6A2L	a	b
MAIN		S	D	0992	87-020-465-080	DIODE,1SS133	a	b
MAIN		S	D	0994	87-020-465-080	DIODE,1SS133	a	b
MAIN		X	FB	0601	88-118-000-080	C-JUMPER,S	a	b
						EZSC1	KSC1	
MAIN		X	FB	0602	88-118-000-080	C-JUMPER,S	a	b
MAIN		X	FB	0603	88-100-000-010	PLATING-JW, 0.58 SN95	a	b
MAIN		O	FFC	0602	88-906-251-110	FF-CABLE,6P 1.25	a	b
MAIN		S	IC	0001	87-A21-364-010	IC,NJM7806FA(A)	a	b
MAIN		S	IC	0601	87-A22-236-040	C-IC,BD3881FV	a	b
MAIN		S	IC	0801	87-A22-060-010	IC,LA1845N-A	a	b
MAIN		S	IC	0861	87-A20-440-040	C-IC,BU1920FS	a	b
MAIN		S	IC	0991	87-A21-928-010	IC,LC72131D-N	a	.
MAIN		O	J	0203	87-A60-238-010	TERMINAL,SP 4P (MSC)	a	b
MAIN		O	J	0602	87-A60-881-010	JACK,PIN 2P MSP 242V05 PBSN	a	b
MAIN		O	J	0832	87-A60-403-010	TERMINAL,ANT PAL 2P HSP-312V05	a	b
MAIN		X	JR	0808	88-108-474-080	C-RES,U 470K-1/16W J	a	.
MAIN		O	L	0201	87-A50-611-010	COIL,1UH K(CS)	a	b
MAIN		O	L	0202	87-A50-611-010	COIL,1UH K(CS)	a	b
MAIN		O	L	0451	87-007-342-010	COIL,OSC 85KHZ BIAS	a	b
MAIN		O	L	0801	87-A50-608-010	COIL,FM DET-N(TOK)	a	b
MAIN		O	L	0802	87-A91-551-010	FLTR,PCFJZH-450 L(TOK)	a	b
MAIN		O	L	0811	87-005-847-080	COIL,2.2UH K CECS	a	b
MAIN		O	L	0832	87-005-847-080	COIL,2.2UH K CECS	a	b
MAIN		O	L	0861	87-005-847-080	COIL,2.2UH K CECS	a	.

ELECTRICAL PARTS LIST - 9/14

! = Δ SAFTY PARTS
 C = Components marked

All components used on this model at the production line are shown in this service manual.
 However, please note that not all components will be available as spare parts for after-sales service.
 Components marked S and O are designated as spare parts for service and will be stocked at the spare parts centers.
 Components marked X and R are not designated as spare parts for after sales service, and will not be stocked at the spare parts centers.

UNIT-NAME	! C	REF-NO	PARTS-NO	PARTS-NAME	SUFFIX&MODEL	
					CX-SNR21	CX-SNR20
					EZSC1	KSC1
MAIN		O L	0901 86-ZA1-612-010	COIL, FM ANT/RF-1-Z	a	b
MAIN		O L	0902 86-ZA1-613-010	COIL, FM ANT/RF-2-Z	a	b
MAIN		O L	0903 87-005-847-080	COIL, 2.2UH K CECS	a	b
MAIN		O L	0904 86-ZA1-612-010	COIL, FM ANT/RF-1-Z	a	b
MAIN		O L	0905 86-ZA1-613-010	COIL, FM ANT/RF-2-Z	a	b
MAIN		O L	0906 87-005-847-080	COIL, 2.2UH K CECS	a	b
MAIN		O L	0907 86-ZA1-614-010	COIL, FM OSC-Z	a	b
MAIN		O L	0908 88-ZA1-624-010	COIL, FM IFT 7-6.2 (COILS)	a	b
MAIN		O L	0941 87-A50-020-010	COIL, ANT LW (COI) 252KHZ	a	b
MAIN		O L	0942 87-A50-019-010	COIL, OSC LW (COI) 856KHZ	a	b
MAIN		O L	0952 87-A50-754-010	COIL, MW ANT (3BLW)	a	b
MAIN		O L	0953 87-A50-755-010	COIL, MW OSC (3BLW)	a	b
MAIN		S Q	0001 87-A30-494-080	TR, 2SA1980G	a	b
MAIN		S Q	0002 87-A30-494-080	TR, 2SA1980G	a	b
MAIN		S Q	0003 87-A30-076-080	C-TR, 2SC3052F	a	b
MAIN		S Q	0006 87-A30-076-080	C-TR, 2SC3052F	a	b
MAIN		S Q	0009 87-A30-494-080	TR, 2SA1980G	a	b
MAIN		S Q	0010 87-A30-076-080	C-TR, 2SC3052F	a	b
MAIN		S Q	0011 89-213-702-010	TR, 2SB1370E	a	b
MAIN		S Q	0012 87-A30-630-080	TR, 2SC5343GL	a	b
					EZSC1	KSC1
MAIN		S Q	0060 87-A30-076-080	C-TR, 2SC3052F	a	b
MAIN		S Q	0061 87-A30-075-080	C-TR, 2SA1235F	a	b
MAIN		S Q	0062 87-A30-076-080	C-TR, 2SC3052F	a	b
MAIN		S Q	0063 87-A30-075-080	C-TR, 2SA1235F	a	b
MAIN		S Q	0064 87-A30-076-080	C-TR, 2SC3052F	a	b
MAIN		S Q	0101 87-A30-675-040	C-TR, 2SD1306NE07TL	a	b
MAIN		S Q	0102 87-A30-675-040	C-TR, 2SD1306NE07TL	a	b
MAIN		S Q	0103 87-A30-075-080	C-TR, 2SA1235F	a	b
MAIN		S Q	0104 87-A30-075-080	C-TR, 2SA1235F	a	b
MAIN		S Q	0105 87-A30-075-080	C-TR, 2SA1235F	a	b
MAIN		S Q	0106 87-A30-075-080	C-TR, 2SA1235F	a	b
MAIN		S Q	0107 87-A30-076-080	C-TR, 2SC3052F	a	b
MAIN		S Q	0108 87-A30-076-080	C-TR, 2SC3052F	a	b
MAIN		S Q	0109 87-A30-076-080	C-TR, 2SC3052F	a	b
MAIN		S Q	0110 87-A30-076-080	C-TR, 2SC3052F	a	b
MAIN		S Q	0111 87-A30-672-080	TR, 2N5551C	a	b
MAIN		S Q	0112 87-A30-672-080	TR, 2N5551C	a	b
MAIN		S Q	0113 87-A30-076-080	C-TR, 2SC3052F	a	b
MAIN		S Q	0114 87-A30-076-080	C-TR, 2SC3052F	a	b
MAIN		S Q	0115 87-A30-662-040	C-TR, 2SD814A (RS)	a	b
					EZSC1	KSC1
MAIN		S Q	0116 87-A30-662-040	C-TR, 2SD814A (RS)	a	b
MAIN		S Q	0117 87-A30-255-010	TR, 2SB1342	a	b
MAIN		S Q	0118 87-A30-255-010	TR, 2SB1342	a	b
MAIN		S Q	0119 87-A30-256-010	TR, 2SD1933	a	b
MAIN		S Q	0120 87-A30-256-010	TR, 2SD1933	a	b
MAIN		S Q	0123 87-A30-663-040	C-TR, 2SB792A (RS)	a	b
MAIN		S Q	0124 87-A30-663-040	C-TR, 2SB792A (RS)	a	b
MAIN		S Q	0126 87-A30-663-040	C-TR, 2SB792A (RS)	a	b
MAIN		S Q	0127 87-A30-076-080	C-TR, 2SC3052F	a	b
MAIN		S Q	0128 87-A30-076-080	C-TR, 2SC3052F	a	b
MAIN		S Q	0130 87-A30-662-040	C-TR, 2SD814A (RS)	a	b
MAIN		S Q	0183 87-A30-186-010	FET, 2SK3053	a	b
MAIN		S Q	0184 87-A30-186-010	FET, 2SK3053	a	b
MAIN		S Q	0185 87-A30-076-080	C-TR, 2SC3052F	a	b
MAIN		S Q	0186 87-A30-075-080	C-TR, 2SA1235F	a	b
MAIN		S Q	0187 87-A30-075-080	C-TR, 2SA1235F	a	b
MAIN		S Q	0235 87-A30-075-080	C-TR, 2SA1235F	a	b
MAIN		S Q	0280 87-A30-538-040	C-TR, SRA2202S	a	b
MAIN		S Q	0281 87-A30-663-040	C-TR, 2SB792A (RS)	a	b
MAIN		S Q	0301 87-A30-091-080	FET, 2SJ460	a	b
					EZSC1	KSC1
MAIN		S Q	0302 87-A30-091-080	FET, 2SJ460	a	b
MAIN		S Q	0303 87-A30-090-080	FET, 2SK2541	a	b
MAIN		S Q	0304 87-A30-090-080	FET, 2SK2541	a	b
MAIN		S Q	0305 87-A30-091-080	FET, 2SJ460	a	b
MAIN		S Q	0306 87-A30-091-080	FET, 2SJ460	a	b
MAIN		S Q	0307 87-A30-090-080	FET, 2SK2541	a	b
MAIN		S Q	0308 87-A30-090-080	FET, 2SK2541	a	b
MAIN		S Q	0309 87-A30-090-080	FET, 2SK2541	a	b
MAIN		S Q	0451 87-A30-630-080	TR, 2SC5343GL	a	b
MAIN		S Q	0452 87-A30-076-080	C-TR, 2SC3052F	a	b
MAIN		S Q	0453 89-333-317-880	TR, 2SC3331 (T/U)	a	b
MAIN		S Q	0454 89-333-317-880	TR, 2SC3331 (T/U)	a	b
MAIN		S Q	0455 87-A30-119-040	C-TR, 2SC3906K R	a	b
MAIN		S Q	0456 87-A30-076-080	C-TR, 2SC3052F	a	b
MAIN		S Q	0601 87-A30-538-040	C-TR, SRA2202S	a	b
MAIN		S Q	0651 87-A30-087-080	C-FET, 2SK2158	a	b
MAIN		S Q	0652 87-A30-087-080	C-FET, 2SK2158	a	b
MAIN		S Q	0653 87-A30-076-080	C-TR, 2SC3052F	a	b
MAIN		S Q	0835 87-A30-521-080	C-TR, 2SC5345SF/S(O)	a	b
MAIN		S Q	0836 87-A30-677-040	C-TR, SRA2207S	a	b

ELECTRICAL PARTS LIST - 10/14

! = Δ SAFTY PARTS
 C = Components marked

All components used on this model at the production line are shown in this service manual.
 However, please note that not all components will be available as spare parts for after-sales service.
 Components marked S and O are designated as spare parts for service and will be stocked at the spare parts centers.
 Components marked X and R are not designated as spare parts for after sales service, and will not be stocked at the spare parts centers.

UNIT-NAME	!	C	REF-NO	PARTS-NO	PARTS-NAME	SUFFIX&MODEL	CX-SNR21	CX-SNR20
							EZSC1	KSC1
MAIN		S	Q	0861	87-A30-076-080	C-TR,2SC3052F	a	.
MAIN		S	Q	0863	87-A30-076-080	C-TR,2SC3052F	a	.
MAIN		S	Q	0901	89-503-602-080	C-FET,2SK360E	a	b
MAIN		S	Q	0902	87-A30-664-080	C-TR,2SC2620B	a	b
MAIN		S	Q	0903	87-A30-664-080	C-TR,2SC2620B	a	b
MAIN		S	Q	0904	87-A30-699-040	C-TR,2SC5477-T22	a	b
MAIN		S	Q	0905	87-A30-664-080	C-TR,2SC2620B	a	b
MAIN		S	Q	0948	87-A30-675-040	C-TR,2SD1306NE07TL	a	b
MAIN		S	Q	0951	87-A30-538-040	C-TR,SRA2202S	a	b
MAIN		S	Q	0952	87-A30-675-040	C-TR,2SD1306NE07TL	a	b
MAIN		S	Q	0953	89-503-602-080	C-FET,2SK360E	a	b
MAIN		S	Q	0981	87-A30-494-080	TR,2SA1980G	a	b
MAIN		S	Q	0982	87-A30-076-080	C-TR,2SC3052F	a	b
MAIN		S	Q	0983	87-A30-076-080	C-TR,2SC3052F	a	b
MAIN		X	R	0001	88-100-000-010	PLATING-JW, 0.58 SN95	a	b
MAIN		X	R	0005	88-100-000-010	PLATING-JW, 0.58 SN95	a	b
MAIN		X	R	0009	88-108-273-080	C-RES,U 27K-1/16W J	a	b
MAIN		X	R	0010	88-108-273-080	C-RES,U 27K-1/16W J	a	b
MAIN		X	R	0011	88-118-472-080	C-RES,S 4.7K-1/10W J	a	b
MAIN		X	R	0012	88-118-472-080	C-RES,S 4.7K-1/10W J	a	b
							EZSC1	KSC1
MAIN		X	R	0013	88-108-472-080	C-RES,U 4.7K-1/16W J	a	b
MAIN		X	R	0014	88-118-100-080	C-RES,S 10-1/10W J	a	b
MAIN		X	R	0015	88-121-104-080	RES,100K-1/8W J	a	b
MAIN		X	R	0016	88-108-104-080	C-RES,U 100K-1/16W J	a	b
MAIN		X	R	0017	88-108-104-080	C-RES,U 100K-1/16W J	a	b
MAIN		X	R	0018	88-108-104-080	C-RES,U 100K-1/16W J	a	b
MAIN		X	R	0019	88-108-104-080	C-RES,U 100K-1/16W J	a	b
MAIN		X	R	0024	88-118-103-080	C-RES,S 10K-1/10W J	a	b
MAIN		X	R	0026	88-108-472-080	C-RES,U 4.7K-1/16W J	a	b
MAIN		X	R	0027	88-118-000-080	C-JUMPER,S	a	b
MAIN		X	R	0028	88-108-221-080	C-RES,U 220-1/16W J	a	b
MAIN		O	R	0029	88-108-223-080	C-RES,U 22K-1/16W J	a	b
MAIN		X	R	0031	88-121-154-080	RES,150K-1/8W J	a	b
MAIN		X	R	0032	88-108-472-080	C-RES,U 4.7K-1/16W J	a	b
MAIN		O	R	0035	88-108-123-080	C-RES,U 12K-1/16W J	a	b
MAIN		X	R	0037	88-118-102-080	C-RES,S 1K-1/10W J	a	b
MAIN		X	R	0038	88-118-102-080	C-RES,S 1K-1/10W J	a	b
MAIN		X	R	0042	88-121-391-080	RES,390-1/8W J	a	b
MAIN		X	R	0043	88-121-391-080	RES,390-1/8W J	a	b
MAIN		X	R	0044	88-121-391-080	RES,390-1/8W J	a	b
							EZSC1	KSC1
MAIN		X	R	0045	88-121-391-080	RES,390-1/8W J	a	b
MAIN		X	R	0046	88-121-471-080	RES,470-1/8W J	a	b
MAIN		O	R	0050	88-108-153-080	C-RES,U 15K-1/16W J	a	b
MAIN		O	R	0051	88-108-102-080	C-RES,U 1K-1/16W J	a	b
MAIN		O	R	0052	88-108-102-080	C-RES,U 1K-1/16W J	a	b
MAIN		X	R	0053	88-118-683-080	C-RES,S 68K-1/10W J	a	b
MAIN		X	R	0054	88-118-822-080	C-RES,S 8.2K-1/10W J	a	b
MAIN		X	R	0055	88-121-152-080	RES,1.5K-1/8W J	a	b
MAIN		X	R	0056	88-118-680-080	C-RES,S 68-1/10W J	a	b
MAIN		X	R	0057	88-108-472-080	C-RES,U 4.7K-1/16W J	a	b
MAIN		X	R	0058	88-118-103-080	C-RES,S 10K-1/10W J	a	b
MAIN		X	R	0059	88-108-221-080	C-RES,U 220-1/16W J	a	b
MAIN		X	R	0060	88-108-471-080	C-RES,U 470-1/16W J	a	b
MAIN		O	R	0061	88-108-103-080	C-RES,U 10K-1/16W J	a	b
MAIN		O	R	0062	88-108-223-080	C-RES,U 22K-1/16W J	a	b
MAIN		O	R	0063	88-108-223-080	C-RES,U 22K-1/16W J	a	b
MAIN		O	R	0064	88-108-103-080	C-RES,U 10K-1/16W J	a	b
MAIN		O	R	0065	88-108-123-080	C-RES,U 12K-1/16W J	a	b
MAIN		X	R	0066	88-108-104-080	C-RES,U 100K-1/16W J	a	b
MAIN		O	R	0067	88-108-103-080	C-RES,U 10K-1/16W J	a	b
							EZSC1	KSC1
MAIN		X	R	0068	88-128-152-080	C-RES, 1.5K-1/8W J	a	b
MAIN		X	R	0069	88-128-152-080	C-RES, 1.5K-1/8W J	a	b
MAIN		O	R	0076	88-108-103-080	C-RES,U 10K-1/16W J	a	b
MAIN		X	R	0078	88-108-393-080	C-RES,U 39K-1/16W J	a	b
MAIN		O	R	0079	88-108-103-080	C-RES,U 10K-1/16W J	a	b
MAIN		O	R	0081	88-108-101-080	C-RES,U 100-1/16W J	a	b
MAIN		O	R	0085	88-108-103-080	C-RES,U 10K-1/16W J	a	b
MAIN		X	R	0093	88-108-683-080	C-RES,U 68K-1/16W J	a	b
MAIN		X	R	0094	88-108-393-080	C-RES,U 39K-1/16W J	a	b
MAIN		O	R	0095	88-108-103-080	C-RES,U 10K-1/16W J	a	b
MAIN		X	R	0096	88-108-683-080	C-RES,U 68K-1/16W J	a	b
MAIN		X	R	0103	88-108-393-080	C-RES,U 39K-1/16W J	a	b
MAIN		X	R	0104	88-108-393-080	C-RES,U 39K-1/16W J	a	b
MAIN		X	R	0105	88-108-273-080	C-RES,U 27K-1/16W J	a	b
MAIN		X	R	0106	88-108-273-080	C-RES,U 27K-1/16W J	a	b
MAIN		O	R	0107	88-108-101-080	C-RES,U 100-1/16W J	a	b
MAIN		O	R	0108	88-108-101-080	C-RES,U 100-1/16W J	a	b
MAIN		X	R	0111	88-118-152-080	C-RES,S 1.5K-1/10W J	a	b
MAIN		X	R	0112	88-118-152-080	C-RES,S 1.5K-1/10W J	a	b
MAIN		X	R	0113	88-118-273-080	C-RES,S 27K-1/10W J	a	b

ELECTRICAL PARTS LIST - 11/14

! = Δ SAFTY PARTS
 C = Components marked

All components used on this model at the production line are shown in this service manual.
 However, please note that not all components will be available as spare parts for after-sales service.
 Components marked S and O are designated as spare parts for service and will be stocked at the spare parts centers.
 Components marked X and R are not designated as spare parts for after sales service, and will not be stocked at the spare parts centers.

UNIT-NAME	! C	REF-NO	PARTS-NO	PARTS-NAME	SUFFIX&MODEL	
					CX-SNR21	CX-SNR20
					EZSC1	KSC1
MAIN	X R	0114	88-118-273-080	C-RES,S 27K-1/10W J	a	b
MAIN	X R	0115	88-128-222-080	C-RES, 2.2K-1/8W J	a	b
MAIN	X R	0116	88-128-222-080	C-RES, 2.2K-1/8W J	a	b
MAIN	O R	0117	88-108-103-080	C-RES,U 10K-1/16W J	a	b
MAIN	O R	0118	88-108-103-080	C-RES,U 10K-1/16W J	a	b
MAIN	X R	0119	88-118-101-080	C-RES,S 100-1/10W J	a	b
MAIN	X R	0120	88-118-101-080	C-RES,S 100-1/10W J	a	b
MAIN	X R	0121	88-118-101-080	C-RES,S 100-1/10W J	a	b
MAIN	X R	0122	88-118-101-080	C-RES,S 100-1/10W J	a	b
MAIN	X R	0123	88-128-222-080	C-RES, 2.2K-1/8W J	a	b
MAIN	X R	0124	88-128-222-080	C-RES, 2.2K-1/8W J	a	b
MAIN	X R	0125	88-128-102-080	C-RES, 1K-1/8W J	a	b
MAIN	X R	0126	88-128-102-080	C-RES, 1K-1/8W J	a	b
MAIN	X R	0127	88-118-390-080	C-RES,S 39-1/10W J	a	b
MAIN	X R	0128	88-118-390-080	C-RES,S 39-1/10W J	a	b
MAIN	O R	0129	87-A00-258-080	RES,M/F 0.22-1W J	a	b
MAIN	O R	0130	87-A00-258-080	RES,M/F 0.22-1W J	a	b
MAIN	O R	0131	87-A00-258-080	RES,M/F 0.22-1W J	a	b
MAIN	O R	0132	87-A00-258-080	RES,M/F 0.22-1W J	a	b
MAIN	X R	0133	88-108-222-080	C-RES,U 2.2K-1/16W J	a	b
					EZSC1	KSC1
MAIN	X R	0134	88-108-222-080	C-RES,U 2.2K-1/16W J	a	b
MAIN	X R	0135	88-108-152-080	C-RES,U 1.5K-1/16W J	a	b
MAIN	X R	0136	88-108-152-080	C-RES,U 1.5K-1/16W J	a	b
MAIN	O R	0137	88-108-101-080	C-RES,U 100-1/16W J	a	b
MAIN	O R	0138	88-108-101-080	C-RES,U 100-1/16W J	a	b
MAIN	X R	0139	88-108-682-080	C-RES,U 6.8K-1/16W J	a	b
MAIN	X R	0140	88-128-682-080	C-RES, 6.8K-1/8W J	a	b
MAIN	X R	0141	88-118-102-080	C-RES,S 1K-1/10W J	a	b
MAIN	X R	0142	88-118-102-080	C-RES,S 1K-1/10W J	a	b
MAIN	X R	0143	88-108-392-080	C-RES,U 3.9K-1/16W J	a	b
MAIN	O R	0145	88-108-123-080	C-RES,U 12K-1/16W J	a	b
MAIN	O R	0146	88-108-123-080	C-RES,U 12K-1/16W J	a	b
MAIN	X R	0149	88-108-392-080	C-RES,U 3.9K-1/16W J	a	b
MAIN	O R	0151	88-108-473-080	C-RES,U 47K-1/16W J	a	b
MAIN	O R	0152	88-108-473-080	C-RES,U 47K-1/16W J	a	b
MAIN	X R	0153	88-128-272-080	C-RES, 2.7K-1/8W J	a	b
MAIN	X R	0157	88-108-472-080	C-RES,U 4.7K-1/16W J	a	b
MAIN	X R	0158	88-108-472-080	C-RES,U 4.7K-1/16W J	a	b
MAIN	O R	0159	88-108-103-080	C-RES,U 10K-1/16W J	a	b
MAIN	X R	0160	88-121-103-080	RES,10K-1/8W J	a	b
					EZSC1	KSC1
MAIN	X R	0161	88-108-472-080	C-RES,U 4.7K-1/16W J	a	b
MAIN	X R	0162	88-108-472-080	C-RES,U 4.7K-1/16W J	a	b
MAIN	X R	0163	88-108-472-080	C-RES,U 4.7K-1/16W J	a	b
MAIN	X R	0164	88-108-472-080	C-RES,U 4.7K-1/16W J	a	b
MAIN	X R	0165	88-108-152-080	C-RES,U 1.5K-1/16W J	a	b
MAIN	X R	0166	88-108-152-080	C-RES,U 1.5K-1/16W J	a	b
MAIN	O R	0167	88-108-103-080	C-RES,U 10K-1/16W J	a	b
MAIN	X R	0168	88-118-473-080	C-RES,S 47K-1/10W J	a	b
MAIN	X R	0171	88-118-222-080	C-RES,S 2.2K-1/10W J	a	b
MAIN	X R	0172	88-118-222-080	C-RES,S 2.2K-1/10W J	a	b
MAIN	X R	0173	88-118-182-080	C-RES,S 1.8K-1/10W J	a	b
MAIN	X R	0174	88-118-182-080	C-RES,S 1.8K-1/10W J	a	b
MAIN	X R	0175	88-118-331-080	C-RES,S 330-1/10W J	a	b
MAIN	X R	0176	88-118-331-080	C-RES,S 330-1/10W J	a	b
MAIN	X R	0177	88-128-222-080	C-RES, 2.2K-1/8W J	a	b
MAIN	X R	0178	88-118-103-080	C-RES,S 10K-1/10W J	a	b
MAIN	O R	0179	88-108-102-080	C-RES,U 1K-1/16W J	a	b
MAIN	O R	0180	88-108-102-080	C-RES,U 1K-1/16W J	a	b
MAIN	X R	0181	88-108-222-080	C-RES,U 2.2K-1/16W J	a	b
MAIN	X R	0182	88-108-222-080	C-RES,U 2.2K-1/16W J	a	b
					EZSC1	KSC1
MAIN	X R	0184	88-118-102-080	C-RES,S 1K-1/10W J	a	b
MAIN	O R	0185	88-108-332-080	C-RES,U 3.3K-1/16W J	a	b
MAIN	X R	0186	88-118-102-080	C-RES,S 1K-1/10W J	a	b
MAIN	X R	0187	88-118-103-080	C-RES,S 10K-1/10W J	a	b
MAIN	X R	0188	88-118-222-080	C-RES,S 2.2K-1/10W J	a	b
MAIN	X R	0189	88-128-272-080	C-RES, 2.7K-1/8W J	a	b
MAIN	X R	0190	88-128-272-080	C-RES, 2.7K-1/8W J	a	b
MAIN	X R	0192	88-128-222-080	C-RES, 2.2K-1/8W J	a	b
MAIN	O R	0193	88-108-103-080	C-RES,U 10K-1/16W J	a	b
MAIN	O R	0194	88-108-103-080	C-RES,U 10K-1/16W J	a	b
MAIN	O R	0195	88-108-473-080	C-RES,U 47K-1/16W J	a	b
MAIN	O R	0196	88-108-473-080	C-RES,U 47K-1/16W J	a	b
MAIN	O R	0197	88-108-473-080	C-RES,U 47K-1/16W J	a	b
MAIN	O R	0198	88-108-473-080	C-RES,U 47K-1/16W J	a	b
MAIN	X R	0199	88-108-225-080	C-RES,U 2.2M-1/16W J	a	b
MAIN	X R	0217	88-108-683-080	C-RES,U 68K-1/16W J	a	b
MAIN	X R	0218	88-108-105-080	C-RES,U 1M-1/16W J	a	b
MAIN	X R	0219	88-108-000-080	C-JUMPER,U	a	b
MAIN	X R	0247	88-130-100-080	RES,10-1/4W J	a	b
MAIN	X R	0248	88-130-100-080	RES,10-1/4W J	a	b

ELECTRICAL PARTS LIST - 12/14

! = Δ SAFTY PARTS
 C = Components marked

All components used on this model at the production line are shown in this service manual.
 However, please note that not all components will be available as spare parts for after-sales service.
 Components marked S and O are designated as spare parts for service and will be stocked at the spare parts centers.
 Components marked X and R are not designated as spare parts for after sales service, and will not be stocked at the spare parts centers.

UNIT-NAME	! C	REF-NO	PARTS-NO	PARTS-NAME	SUFFIX&MODEL	
					CX-SNR21	CX-SNR20
					EZSC1	KSC1
MAIN	X R	0249	88-128-100-080	C-RES, 10-1/8W J	a	b
MAIN	X R	0250	88-128-100-080	C-RES, 10-1/8W J	a	b
MAIN	O R	0280	88-108-473-080	C-RES,U 47K-1/16W J	a	b
MAIN	X R	0281	88-108-222-080	C-RES,U 2.2K-1/16W J	a	b
MAIN	O R	0282	88-108-103-080	C-RES,U 10K-1/16W J	a	b
MAIN	O R	0283	88-108-224-080	C-RES,U 220K-1/16W J	a	b
MAIN	O R	0284	88-108-224-080	C-RES,U 220K-1/16W J	a	b
MAIN	O R	0285	88-108-223-080	C-RES,U 22K-1/16W J	a	b
MAIN	O R	0286	88-108-473-080	C-RES,U 47K-1/16W J	a	b
MAIN	O R	0287	88-108-473-080	C-RES,U 47K-1/16W J	a	b
MAIN	X R	0301	88-108-393-080	C-RES,U 39K-1/16W J	a	b
MAIN	X R	0302	88-108-393-080	C-RES,U 39K-1/16W J	a	b
MAIN	O R	0303	88-108-823-080	C-RES,U 82K-1/16W J	a	b
MAIN	O R	0304	88-108-823-080	C-RES,U 82K-1/16W J	a	b
MAIN	O R	0305	88-108-224-080	C-RES,U 220K-1/16W J	a	b
MAIN	X R	0451	88-108-222-080	C-RES,U 2.2K-1/16W J	a	b
MAIN	X R	0453	88-108-472-080	C-RES,U 4.7K-1/16W J	a	b
MAIN	X R	0454	88-121-829-080	RES, 8.2-1/8W J	a	b
MAIN	X R	0455	88-108-183-080	C-RES,U 18K-1/16W J	a	b
MAIN	X R	0456	88-108-183-080	C-RES,U 18K-1/16W J	a	b
					EZSC1	KSC1
MAIN	X R	0457	88-108-104-080	C-RES,U 100K-1/16W J	a	b
MAIN	O R	0458	88-108-563-080	C-RES,U 56K-1/16W J	a	b
MAIN	X R	0459	88-108-472-080	C-RES,U 4.7K-1/16W J	a	b
MAIN	X R	0461	88-108-472-080	C-RES,U 4.7K-1/16W J	a	b
MAIN	X R	0462	88-108-471-080	C-RES,U 470-1/16W J	a	b
MAIN	X R	0467	88-108-472-080	C-RES,U 4.7K-1/16W J	a	b
MAIN	O R	0468	88-108-272-080	C-RES,U 2.7K-1/16W J	a	b
MAIN	X R	0469	88-108-150-080	C-RES,U 15-1/16W J	a	b
MAIN	X R	0601	88-108-680-080	C-RES,U 68-1/16W J	a	b
MAIN	X R	0602	88-108-680-080	C-RES,U 68-1/16W J	a	b
MAIN	X R	0603	88-108-394-080	C-RES,U 390K-1/16W J	a	b
MAIN	X R	0604	88-108-394-080	C-RES,U 390K-1/16W J	a	b
MAIN	X R	0605	88-108-122-080	C-RES,U 1.2K-1/16W J	a	b
MAIN	X R	0606	88-108-122-080	C-RES,U 1.2K-1/16W J	a	b
MAIN	X R	0607	88-108-183-080	C-RES,U 18K-1/16W J	a	b
MAIN	X R	0608	88-108-183-080	C-RES,U 18K-1/16W J	a	b
MAIN	X R	0609	88-108-472-080	C-RES,U 4.7K-1/16W J	a	b
MAIN	X R	0610	88-108-472-080	C-RES,U 4.7K-1/16W J	a	b
MAIN	O R	0611	88-108-223-080	C-RES,U 22K-1/16W J	a	b
MAIN	O R	0612	88-108-223-080	C-RES,U 22K-1/16W J	a	b
					EZSC1	KSC1
MAIN	X R	0613	88-108-273-080	C-RES,U 27K-1/16W J	a	b
MAIN	X R	0614	88-108-273-080	C-RES,U 27K-1/16W J	a	b
MAIN	O R	0615	88-108-153-080	C-RES,U 15K-1/16W J	a	b
MAIN	O R	0616	88-108-153-080	C-RES,U 15K-1/16W J	a	b
MAIN	O R	0617	88-108-153-080	C-RES,U 15K-1/16W J	a	b
MAIN	O R	0619	88-108-153-080	C-RES,U 15K-1/16W J	a	b
MAIN	O R	0621	88-108-332-080	C-RES,U 3.3K-1/16W J	a	b
MAIN	O R	0622	88-108-332-080	C-RES,U 3.3K-1/16W J	a	b
MAIN	X R	0623	88-108-182-080	C-RES,U 1.8K-1/16W J	a	b
MAIN	X R	0624	88-108-182-080	C-RES,U 1.8K-1/16W J	a	b
MAIN	O R	0625	88-108-103-080	C-RES,U 10K-1/16W J	a	b
MAIN	O R	0626	88-108-103-080	C-RES,U 10K-1/16W J	a	b
MAIN	X R	0627	88-108-222-080	C-RES,U 2.2K-1/16W J	a	b
MAIN	X R	0628	88-108-222-080	C-RES,U 2.2K-1/16W J	a	b
MAIN	O R	0629	88-108-103-080	C-RES,U 10K-1/16W J	a	b
MAIN	O R	0630	88-108-103-080	C-RES,U 10K-1/16W J	a	b
MAIN	X R	0631	88-108-222-080	C-RES,U 2.2K-1/16W J	a	b
MAIN	X R	0632	88-108-222-080	C-RES,U 2.2K-1/16W J	a	b
MAIN	O R	0633	88-108-272-080	C-RES,U 2.7K-1/16W J	a	b
MAIN	O R	0634	88-108-272-080	C-RES,U 2.7K-1/16W J	a	b
					EZSC1	KSC1
MAIN	O R	0635	88-108-102-080	C-RES,U 1K-1/16W J	a	b
MAIN	O R	0636	88-108-102-080	C-RES,U 1K-1/16W J	a	b
MAIN	O R	0637	88-108-102-080	C-RES,U 1K-1/16W J	a	b
MAIN	O R	0638	88-108-102-080	C-RES,U 1K-1/16W J	a	b
MAIN	X R	0639	88-108-183-080	C-RES,U 18K-1/16W J	a	b
MAIN	X R	0640	88-108-183-080	C-RES,U 18K-1/16W J	a	b
MAIN	X R	0641	88-121-223-080	RES, 22K-1/8W J	a	b
MAIN	X R	0642	88-108-222-080	C-RES,U 2.2K-1/16W J	a	b
MAIN	X R	0643	88-108-104-080	C-RES,U 100K-1/16W J	a	b
MAIN	X R	0644	88-108-104-080	C-RES,U 100K-1/16W J	a	b
MAIN	O R	0649	88-108-332-080	C-RES,U 3.3K-1/16W J	a	b
MAIN	O R	0650	88-108-332-080	C-RES,U 3.3K-1/16W J	a	b
MAIN	O R	0651	88-108-101-080	C-RES,U 100-1/16W J	a	b
MAIN	O R	0652	88-108-101-080	C-RES,U 100-1/16W J	a	b
MAIN	X R	0656	88-121-394-080	RES, 390K-1/8W J	a	b
MAIN	X R	0657	88-108-274-080	C-RES,U 270K-1/16W J	a	b
MAIN	X R	0658	88-108-274-080	C-RES,U 270K-1/16W J	a	b
MAIN	X R	0659	88-108-394-080	C-RES,U 390K-1/16W J	a	b
MAIN	X R	0660	88-108-274-080	C-RES,U 270K-1/16W J	a	b
MAIN	X R	0661	88-108-392-080	C-RES,U 3.9K-1/16W J	a	b

ELECTRICAL PARTS LIST - 13/14

! = Δ SAFTY PARTS
 C = Components marked

All components used on this model at the production line are shown in this service manual.
 However, please note that not all components will be available as spare parts for after-sales service.
 Components marked S and O are designated as spare parts for service and will be stocked at the spare parts centers.
 Components marked X and R are not designated as spare parts for after sales service, and will not be stocked at the spare parts centers.

UNIT-NAME	! C	REF-NO	PARTS-NO	PARTS-NAME	SUFFIX&MODEL	CX-SNR21	CX-SNR20
						EZSC1	KSC1
MAIN	X R	0662	88-108-392-080	C-RES,U 3.9K-1/16W J	a		b
MAIN	O R	0672	88-108-223-080	C-RES,U 22K-1/16W J	a		b
MAIN	X R	0673	88-108-392-080	C-RES,U 3.9K-1/16W J	a		b
MAIN	X R	0674	88-108-273-080	C-RES,U 27K-1/16W J	a		b
MAIN	O R	0677	88-108-223-080	C-RES,U 22K-1/16W J	a		b
MAIN	O R	0678	88-108-223-080	C-RES,U 22K-1/16W J	a		b
MAIN	X R	0789	88-108-333-080	C-RES,U 33K-1/16W J	a		b
MAIN	O R	0790	87-012-286-080	C-CAP,U 0.01-25 K B GRM	a		b
MAIN	O R	0791	88-108-102-080	C-RES,U 1K-1/16W J	a		b
MAIN	X R	0793	88-108-221-080	C-RES,U 220-1/16W J	a		b
MAIN	X R	0795	88-108-000-080	C-JUMPER,U	a		b
MAIN	O R	0801	88-108-103-080	C-RES,U 10K-1/16W J	a		b
MAIN	O R	0802	88-108-223-080	C-RES,U 22K-1/16W J	a		b
MAIN	X R	0803	88-128-183-080	C-RES, 18K-1/8W J	a		b
MAIN	X R	0804	88-108-000-080	C-JUMPER,U	a		b
MAIN	O R	0805	88-108-332-080	C-RES,U 3.3K-1/16W J	a		b
MAIN	X R	0806	88-108-682-080	C-RES,U 6.8K-1/16W J	a		b
MAIN	O R	0809	88-108-102-080	C-RES,U 1K-1/16W J	a		b
MAIN	O R	0810	88-108-102-080	C-RES,U 1K-1/16W J	a		b
MAIN	X R	0811	88-108-000-080	C-JUMPER,U	a		b
						EZSC1	KSC1
MAIN	X R	0812	88-108-000-080	C-JUMPER,U	a		b
MAIN	O R	0813	88-108-224-080	C-RES,U 220K-1/16W J	a		b
MAIN	X R	0814	88-108-222-080	C-RES,U 2.2K-1/16W J	a		b
MAIN	X R	0815	88-121-682-080	RES,6.8K-1/8W J	a		b
MAIN	O R	0818	88-108-103-080	C-RES,U 10K-1/16W J	a		b
MAIN	X R	0821	88-108-000-080	C-JUMPER,U	a		b
MAIN	O R	0823	88-108-473-080	C-RES,U 47K-1/16W J	a		b
MAIN	O R	0826	88-108-223-080	C-RES,U 22K-1/16W J	a		b
MAIN	X R	0832	88-108-391-080	C-RES,U 390-1/16W J	a		b
MAIN	X R	0840	88-108-331-080	C-RES,U 330-1/16W J	a		b
MAIN	O R	0850	88-108-103-080	C-RES,U 10K-1/16W J	a		b
MAIN	X R	0851	88-118-470-080	C-RES,S 47-1/10W J	a		b
MAIN	O R	0853	88-108-102-080	C-RES,U 1K-1/16W J	a		b
MAIN	X R	0854	88-108-331-080	C-RES,U 330-1/16W J	a		b
MAIN	X R	0855	88-108-183-080	C-RES,U 18K-1/16W J	a		b
MAIN	O R	0856	88-108-103-080	C-RES,U 10K-1/16W J	a		b
MAIN	X R	0857	88-108-181-080	C-RES,U 180-1/16W J	a		b
MAIN	X R	0858	88-108-271-080	C-RES,U 270-1/16W J	a		b
MAIN	O R	0860	88-108-101-080	C-RES,U 100-1/16W J	a		b
MAIN	X R	0861	88-108-471-080	C-RES,U 470-1/16W J	a		.
						EZSC1	KSC1
MAIN	O R	0862	88-108-272-080	C-RES,U 2.7K-1/16W J	a		.
MAIN	X R	0863	88-108-104-080	C-RES,U 100K-1/16W J	a		.
MAIN	O R	0864	88-108-123-080	C-RES,U 12K-1/16W J	a		.
MAIN	X R	0865	88-108-471-080	C-RES,U 470-1/16W J	a		.
MAIN	X R	0867	88-108-104-080	C-RES,U 100K-1/16W J	a		.
MAIN	X R	0870	88-121-102-080	RES,1K-1/8W J	a		.
MAIN	X R	0871	88-121-102-080	RES,1K-1/8W J	a		.
MAIN	X R	0901	88-108-104-080	C-RES,U 100K-1/16W J	a		b
MAIN	X R	0902	88-108-104-080	C-RES,U 100K-1/16W J	a		b
MAIN	X R	0903	88-108-330-080	C-RES,U 33-1/16W J	a		b
MAIN	O R	0904	88-108-103-080	C-RES,U 10K-1/16W J	a		b
MAIN	O R	0905	88-108-102-080	C-RES,U 1K-1/16W J	a		b
MAIN	X R	0906	88-108-564-080	C-RES,U 560K-1/16W J	a		b
MAIN	X R	0908	88-108-271-080	C-RES,U 270-1/16W J	a		b
MAIN	X R	0909	88-108-181-080	C-RES,U 180-1/16W J	a		b
MAIN	X R	0910	88-108-334-080	C-RES,U 330K-1/16W J	a		b
MAIN	X R	0911	88-108-181-080	C-RES,U 180-1/16W J	a		b
MAIN	X R	0912	88-108-104-080	C-RES,U 100K-1/16W J	a		b
MAIN	X R	0913	88-108-152-080	C-RES,U 1.5K-1/16W J	a		b
MAIN	X R	0914	88-108-472-080	C-RES,U 4.7K-1/16W J	a		b
						EZSC1	KSC1
MAIN	X R	0915	88-108-104-080	C-RES,U 100K-1/16W J	a		b
MAIN	X R	0916	88-108-470-080	C-RES,U 47-1/16W J	a		b
MAIN	O R	0926	88-108-101-080	C-RES,U 100-1/16W J	a		b
MAIN	O R	0944	88-108-101-080	C-RES,U 100-1/16W J	a		b
MAIN	X R	0945	88-108-104-080	C-RES,U 100K-1/16W J	a		b
MAIN	X R	0947	88-108-183-080	C-RES,U 18K-1/16W J	a		b
MAIN	X R	0948	88-108-472-080	C-RES,U 4.7K-1/16W J	a		b
MAIN	O R	0952	88-108-562-080	C-RES,U 5.6K-1/16W J	a		b
MAIN	X R	0954	88-108-222-080	C-RES,U 2.2K-1/16W J	a		b
MAIN	X R	0956	88-108-471-080	C-RES,U 470-1/16W J	a		b
MAIN	X R	0958	88-108-472-080	C-RES,U 4.7K-1/16W J	a		b
MAIN	O R	0959	88-108-103-080	C-RES,U 10K-1/16W J	a		b
MAIN	X R	0962	88-121-102-080	RES,1K-1/8W J	a		b
MAIN	X R	0964	88-108-330-080	C-RES,U 33-1/16W J	a		b
MAIN	O R	0968	88-108-822-080	C-RES,U 8.2K-1/16W J	a		b
MAIN	O R	0969	88-108-102-080	C-RES,U 1K-1/16W J	a		b
MAIN	O R	0973	88-108-102-080	C-RES,U 1K-1/16W J	a		b
MAIN	O R	0975	88-108-562-080	C-RES,U 5.6K-1/16W J	a		b
MAIN	O R	0976	88-108-102-080	C-RES,U 1K-1/16W J	a		b
MAIN	O R	0977	88-108-102-080	C-RES,U 1K-1/16W J	a		b

ELECTRICAL PARTS LIST - 14/14

! = Δ SAFTY PARTS
 C = Components marked

All components used on this model at the production line are shown in this service manual.
 However, please note that not all components will be available as spare parts for after-sales service.
 Components marked S and O are designated as spare parts for service and will be stocked at the spare parts centers.
 Components marked X and R are not designated as spare parts for after sales service, and will not be stocked at the spare parts centers.

UNIT-NAME	! C	REF-NO	PARTS-NO	PARTS-NAME	SUFFIX&MODEL	CX-SNR21	CX-SNR20
					EZSC1	KSC1	
MAIN	X R	0978	88-108-681-080	C-RES,U 680-1/16W J	a	b	
MAIN	O R	0979	88-108-123-080	C-RES,U 12K-1/16W J	a	b	
MAIN	X R	0980	88-108-684-080	C-RES,U 680K-1/16W J	a	b	
MAIN	X R	0981	88-121-471-080	RES,470-1/8W J	a	b	
MAIN	X R	0982	88-108-682-080	C-RES,U 6.8K-1/16W J	a	b	
MAIN	X R	0983	88-108-392-080	C-RES,U 3.9K-1/16W J	a	b	
MAIN	O R	0984	88-108-562-080	C-RES,U 5.6K-1/16W J	a	b	
MAIN	X R	0985	88-121-471-080	RES,470-1/8W J	a	b	
MAIN	X R	0986	88-121-221-080	RES,220-1/8W J	a	b	
MAIN	X R	0987	88-121-472-080	RES,4.7K-1/8W J	a	b	
MAIN	O R	0988	88-108-103-080	C-RES,U 10K-1/16W J	a	b	
MAIN	X R	0989	88-121-102-080	RES,1K-1/8W J	a	b	
MAIN	O R	0990	88-108-563-080	C-RES,U 56K-1/16W J	a	b	
MAIN	O R	0991	87-012-195-080	C-CAP,U 100P-50 J CH GRM	a	b	
MAIN	O R	0992	88-108-103-080	C-RES,U 10K-1/16W J	a	b	
MAIN	O R	0993	87-012-195-080	C-CAP,U 100P-50 J CH GRM	a	b	
MAIN	O R	0994	88-108-103-080	C-RES,U 10K-1/16W J	a	b	
MAIN	O R	0995	87-012-195-080	C-CAP,U 100P-50 J CH GRM	a	b	
MAIN	O R	0996	88-108-103-080	C-RES,U 10K-1/16W J	a	b	
MAIN	X R	0997	88-108-154-080	C-RES,U 150K-1/16W J	a	b	
					EZSC1	KSC1	
MAIN	O R	0998	88-108-102-080	C-RES,U 1K-1/16W J	a	b	
MAIN	O R	0999	88-108-103-080	C-RES,U 10K-1/16W J	a	b	
MAIN	O	SFR0451	87-024-435-080	SFR,33K H RH063MC	a	b	
MAIN	O	SFR0452	87-024-435-080	SFR,33K H RH063MC	a	b	
MAIN	X SH	0901	8C-NF9-619-010	SHLD-CASE,CNF-9 EZ P	a	b	
MAIN	O TC	0942	87-A91-774-080	TRIMMER,PLY 30P 6.8X5.4 CDYL	a	b	
MAIN	O TH	0101	87-A91-042-080	C-THMS,100K 55001	a	b	
MAIN	O TH	0102	87-A91-042-080	C-THMS,100K 55001	a	b	
MAIN	O W	0099	8A-NF9-609-010	F-CABLE,9P 2.5 480MM	a	b	
MAIN	O W	0101	8B-NF1-640-010	F-CABLE,5P 2.5 250MM	a	b	
MAIN	O WH	0001	87-A90-510-010	HLDR,WIRE 2.5-9P	a	b	
MAIN	O WH	0101	87-A90-459-010	HLDR,WIRE 2.5-5P	a	b	
MAIN	O X	0862	87-A70-307-010	VIB,XTAL 4.332MHZ CSA-309ST	a	.	
MAIN	O X	0992	87-A70-306-010	VIB,XTAL 4.500MHZ CSA-309ST	a	b	
POWER	O C	0091	87-012-368-080	C-CAP,S 0.1-50 Z F GRM	a	b	
POWER	S D	0091	87-A40-269-080	C-DIODE,MC2836	a	b	
POWER	S D	0092	87-A40-270-080	C-DIODE,MC2838	a	b	
POWER	X PR	0003	88-100-000-010	PLATING-JW, 0.58 SN95	a	b	
POWER	! O PT	0001	8C-NF9-603-010	PT,CNF-9 EZ	a	b	
POWER	! O PT	0002	8B-MA6-675-010	PT,SUB BMA E (VRK)	a	b	
					EZSC1	KSC1	
POWER	! O RY	0001	87-A91-418-010	RELAY,AC 12V G5PA-1-M	a	b	
POWER	! O T	0001	87-A60-317-010	TERMINAL, 1P MSC	a	b	
POWER	! O T	0002	87-A60-317-010	TERMINAL, 1P MSC	a	b	
POWER	! O WH	0002	87-A90-510-010	HLDR,WIRE 2.5-9P	a	b	

- Regarding connectors, they are not stocked as they are not the initial order items.
The connectors are available after they are supplied from connector manufacturers upon the order is received.

○チップ抵抗部品コード／CHIP RESISTOR PART CODE

チップ抵抗部品コードの成り立ち

Chip Resistor Part Coding

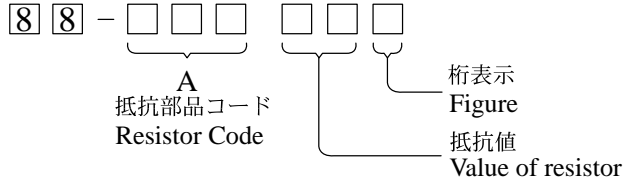

チップ抵抗
Chip resistor

容量 Wattage	種類 Type	許容誤差 Tolerance	記号 Symbol	寸法/Dimensions (mm)			抵抗コード : A Resistor Code : A	
				外形/Form	L	W		t
1/16W	1005	± 5%	CJ		1.0	0.5	0.35	104
1/16W	1608	± 5%	CJ		1.6	0.8	0.45	108
1/10W	2125	± 5%	CJ		2	1.25	0.45	118
1/8W	3216	± 5%	CJ		3.2	1.6	0.55	128

TRANSISTOR ILLUSTRATION

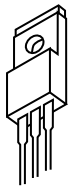

B C E

2SB1342
2SB1370
2SD1933



E C B

2SA1980G
2SA1981Y
2SC3331(T/U)



E C B

2SA1585SR



E C B

2SC5343GL



E C B

2N5551C

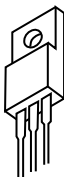

G D S

2SK3053

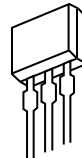

S D G

2SJ460
2SK2541

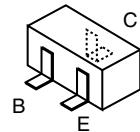

2SA1235F
2SB792A
2SC2620B
2SC3052F
2SC3906KR
2SC5477
2SD814A
2SD1306NE
SRA2202S
SRA2207S

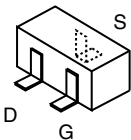

2SK360E

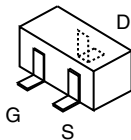

2SK2158

SCHMATIC DIAGRAM - 1/4 (MAIN -1/2, DECK/AMP/HP SECTION)

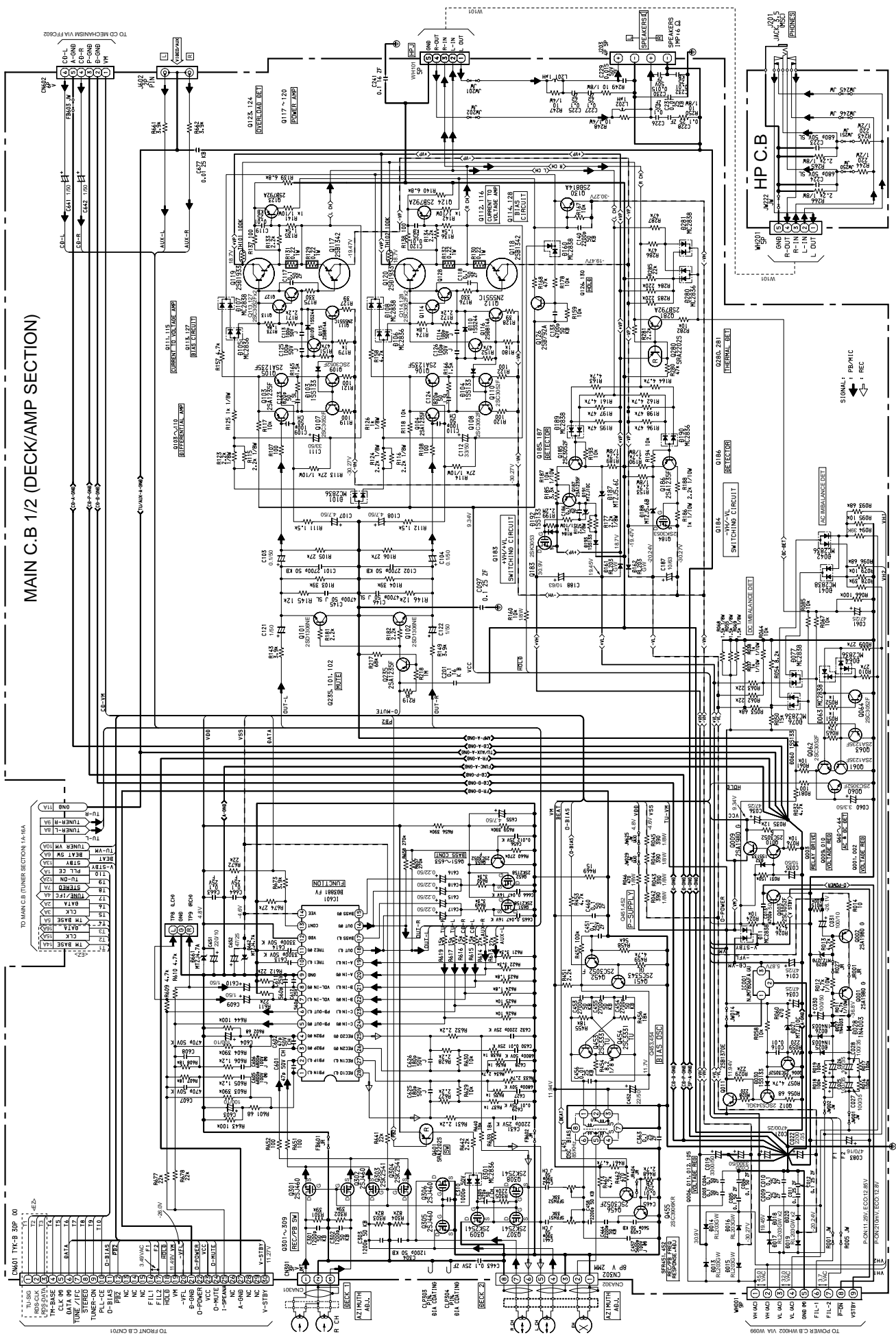

SCHEMATIC DIAGRAM - 2/4 (MAIN -2/2, TUNER SECTION)

MAIN C.B 2/2 (TUNER SECTION)

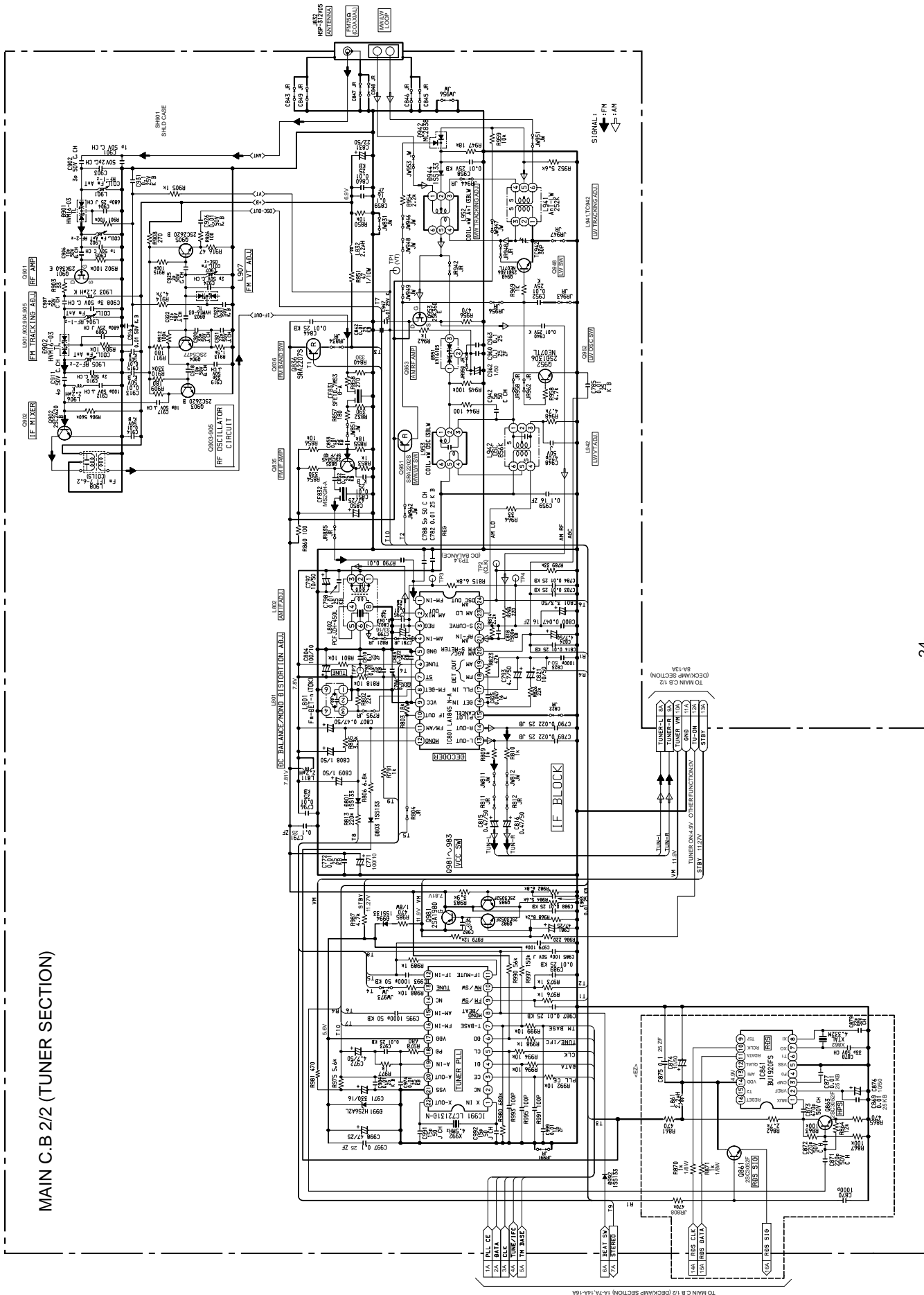

WIRING - 1/4 (MAIN C.B. / HP C.B.)

MAIN C.B.

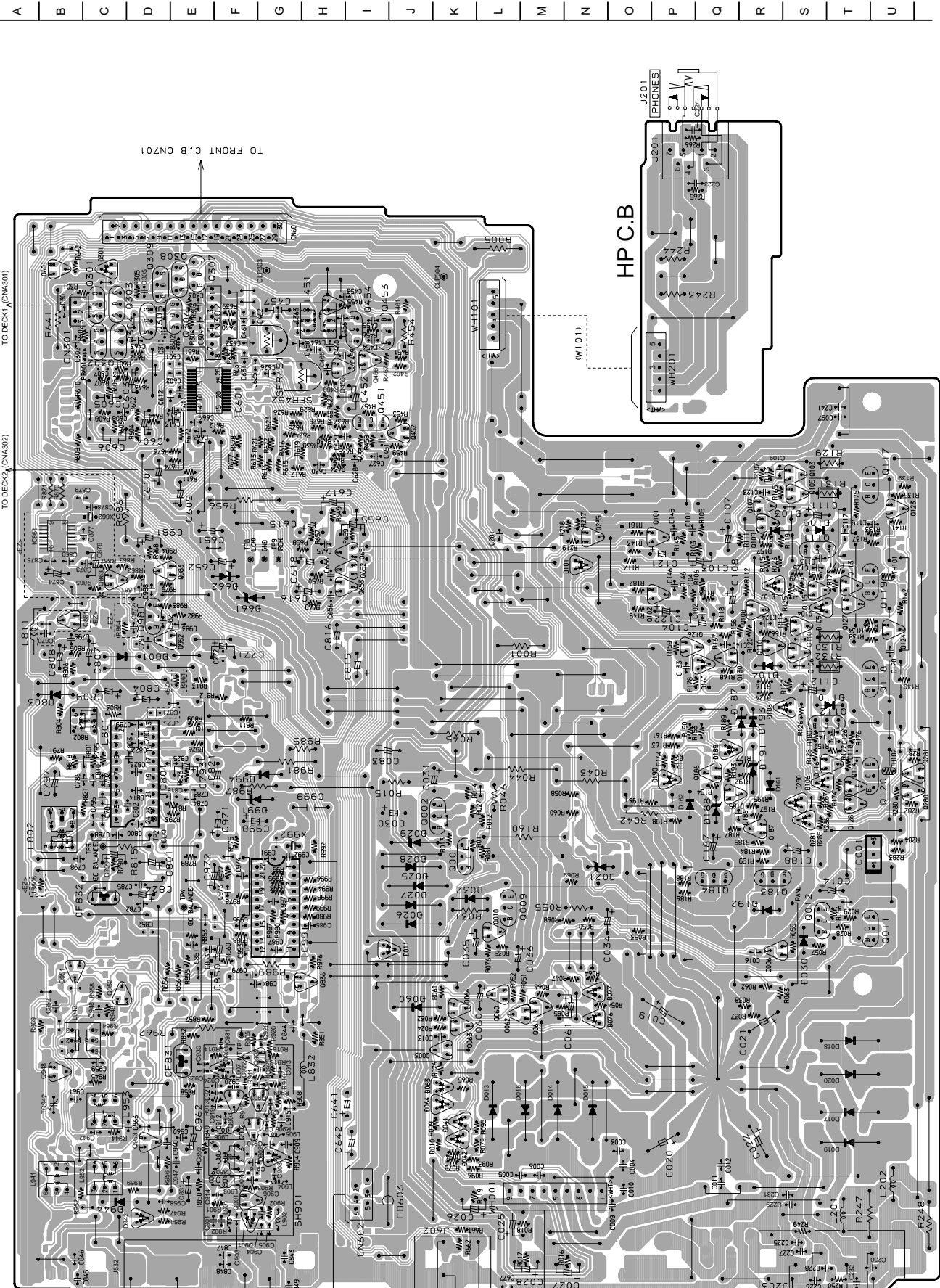

SCHEMATIC DIAGRAM - 3/4 (FRONT, DECK SECTION)

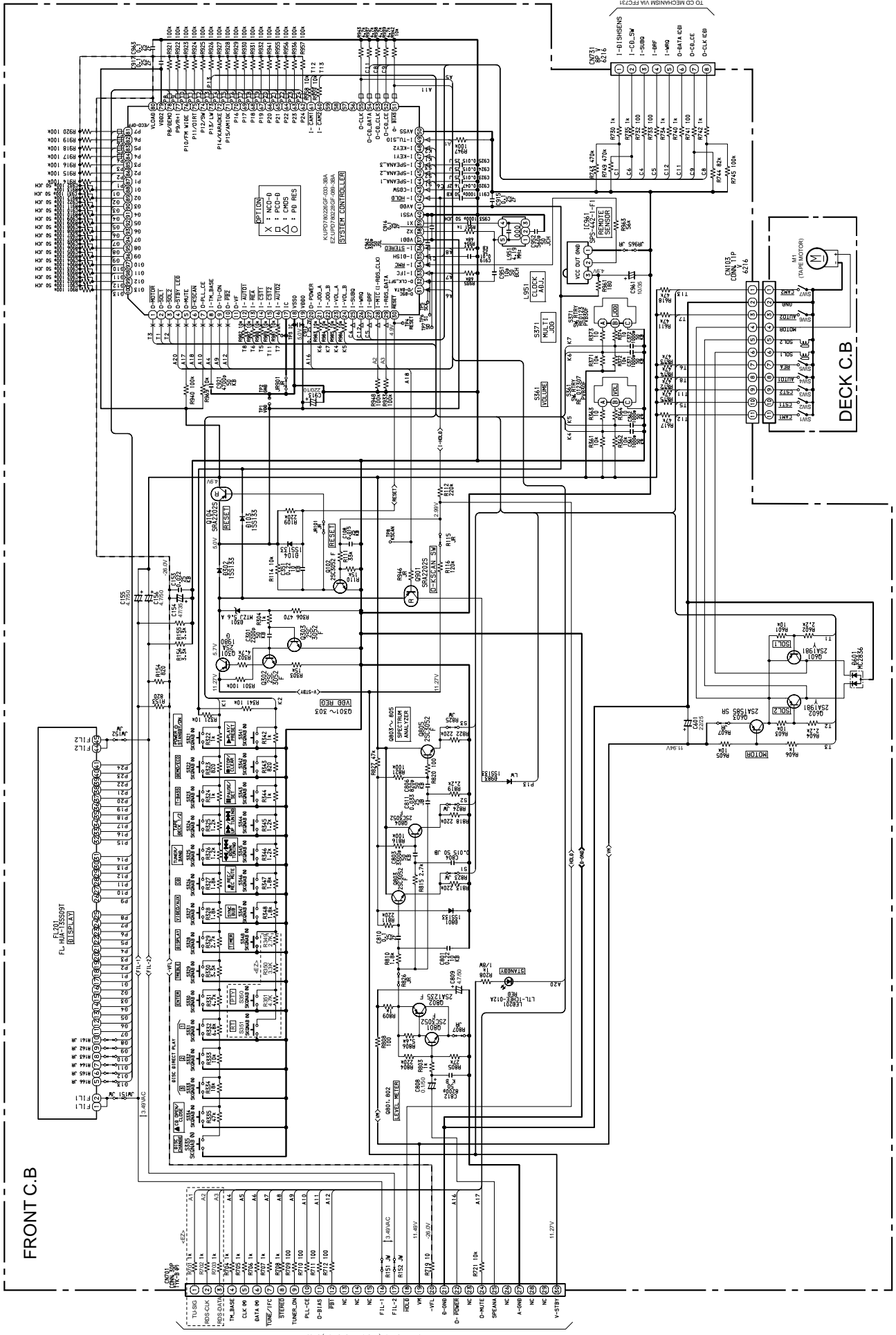

32 31 30 29 28 27 26 25 24 23 22 21 20 19 18 17 16 15 14 13 12 11 10 9 8 7 6 5 4 3 2 1

A B C D E F G H I J K L M N O P Q R S T U

FRONT C.B

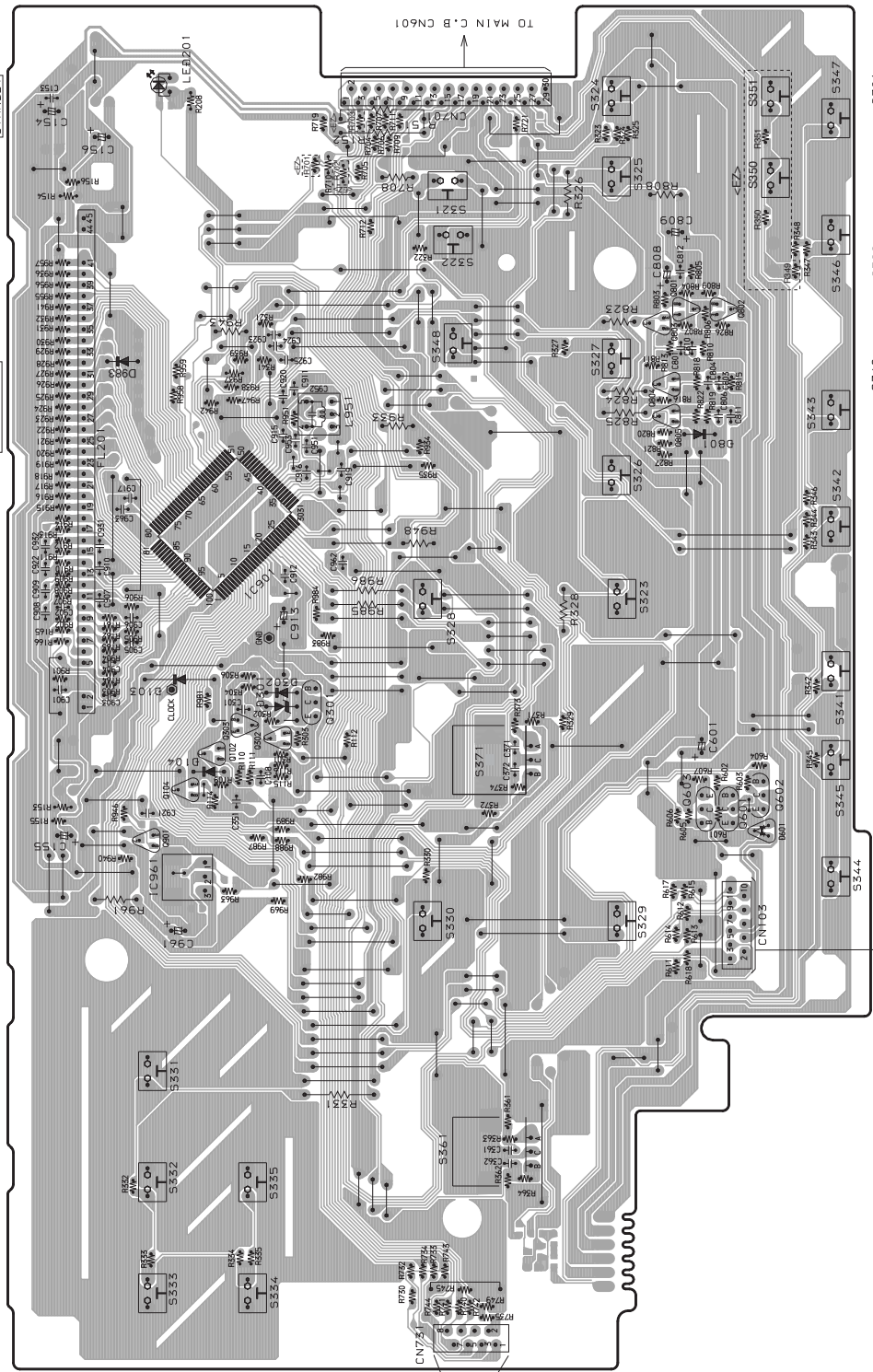

LEB201
STANDBY

FL201
FL DISPLAY

IC961
REMOTE SENSOR

TO MAIN C.B CN601

TO CB MECHANISM
(FC731)

- S321 POWER U STANDBY/ON
- S322 BEMO/ECO
- S323 TIMER
- S324 TAPE/BECK 1/2
- S325 TUNER/BAND
- S326 V/VIDEO/AUX
- S327 CD
- S328 DISPLAY
- S329 TREBLE
- S330 T-BASS
- S331 RT
- S332 REC/REC. MUTE
- S333 DISC DIRECT PLAY
- S334 CB OPEN/CLOSE
- S335 DISC CHANGE
- S336 PAUSE/SET
- S337 STOP/CLEAR
- S338 MULTI JOG
- S339 ENTER
- S340 UP TUNING
- S341 PLAY/PRESET
- S342 DOWN TUNING
- S343 REC/REC. MUTE
- S344 UP TUNING
- S345 T-BASS
- S346 PAUSE/SET
- S347 SYNC. DUB
- S348 TIMER
- S349 BEMO/ECO
- S350 TUNER/BAND
- S351 TAPE/BECK 1/2
- S352 V/VIDEO/AUX
- S353 CD
- S354 DISPLAY
- S355 TREBLE
- S356 T-BASS
- S357 MULTI JOG
- S358 ENTER
- S359 UP TUNING
- S360 PLAY/PRESET
- S361 STOP/CLEAR
- S362 PAUSE/SET
- S363 REC/REC. MUTE
- S364 SYNC. DUB
- S365 TAPE/BECK 1/2
- S366 TUNER/BAND
- S367 BEMO/ECO
- S368 POWER U STANDBY/ON

DECK C.B

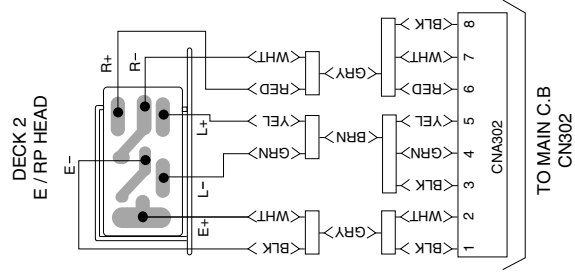
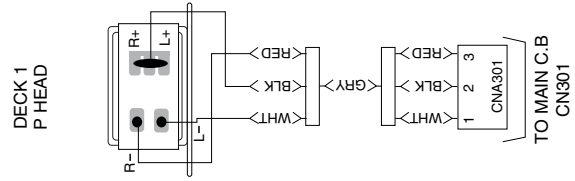
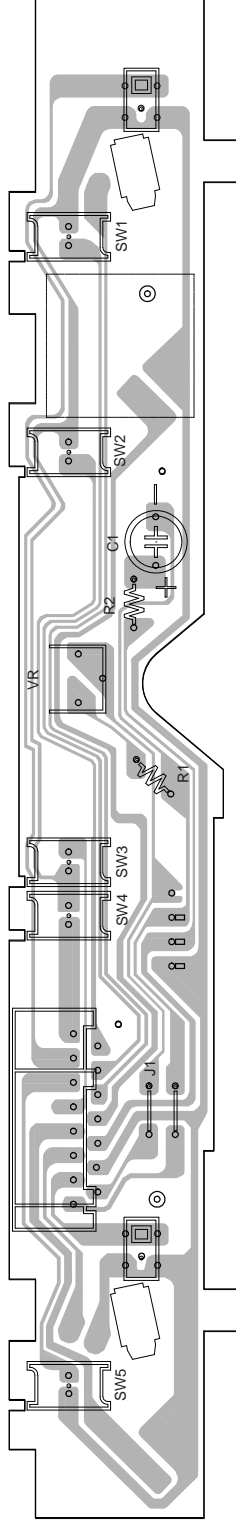

SCHEMATIC DIAGRAM -4/4 (POWER SECTION)

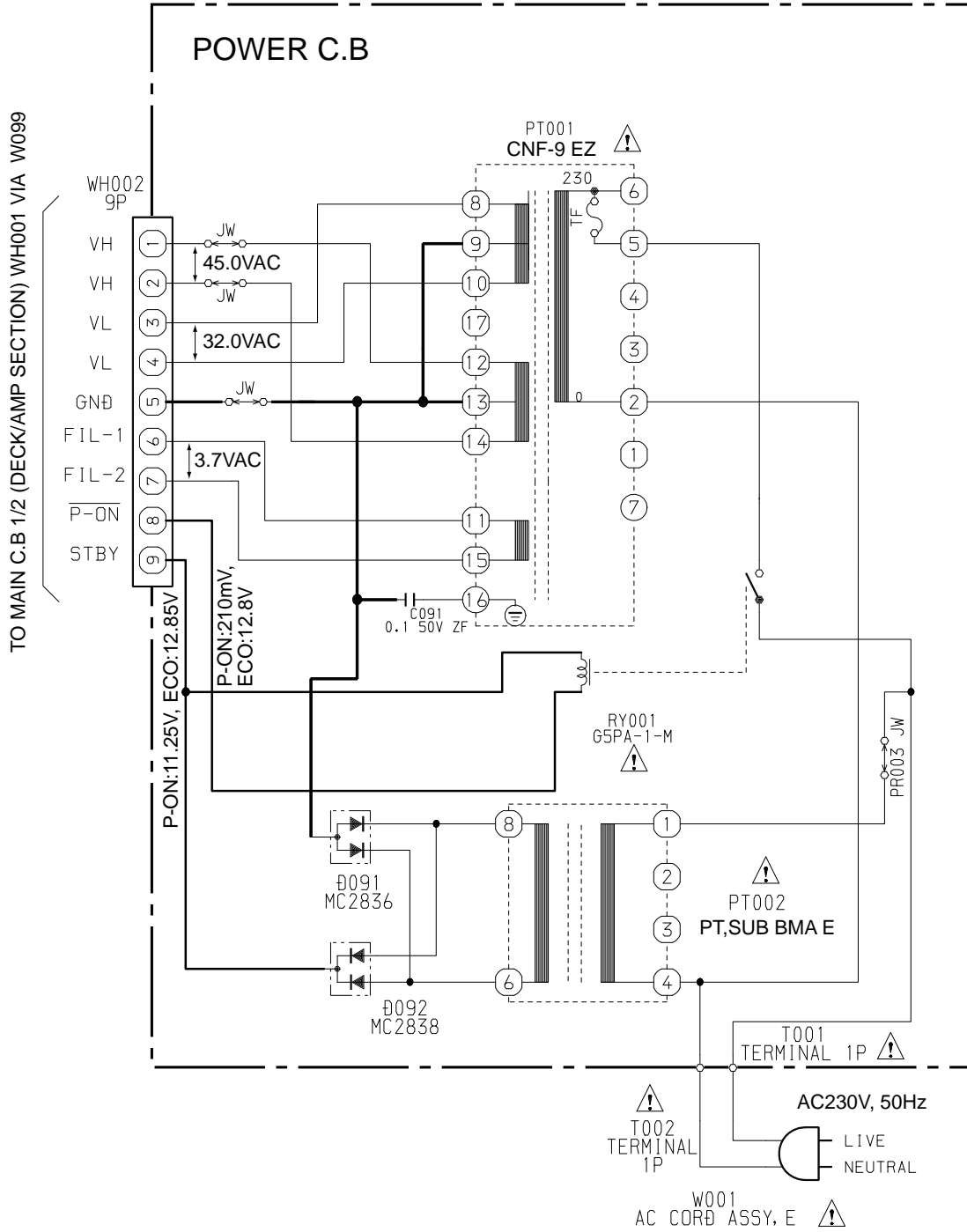

WIRING - 4/4 (POWER C.B)

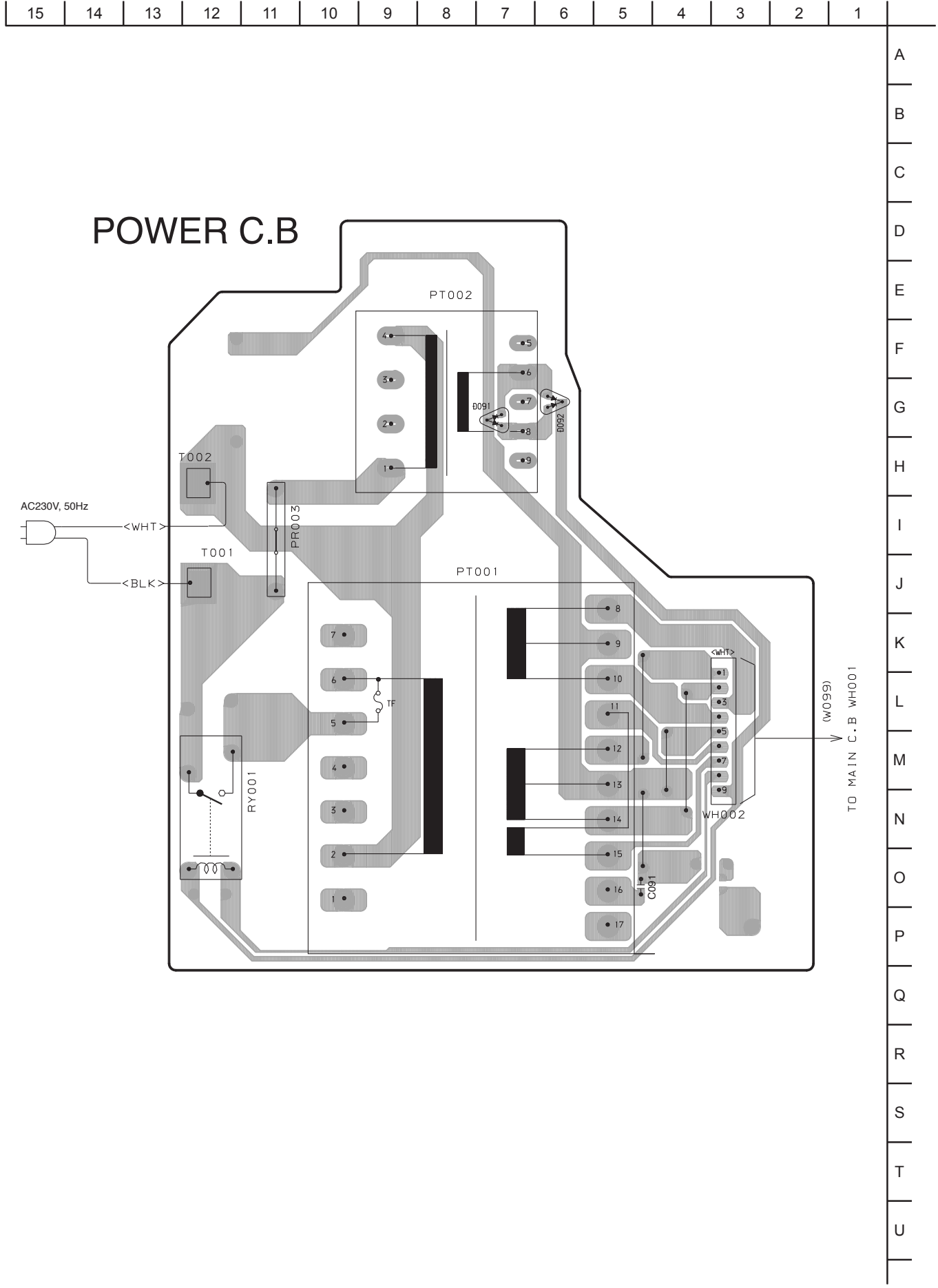

ELECTRICAL ADJUSTMENT -1/7

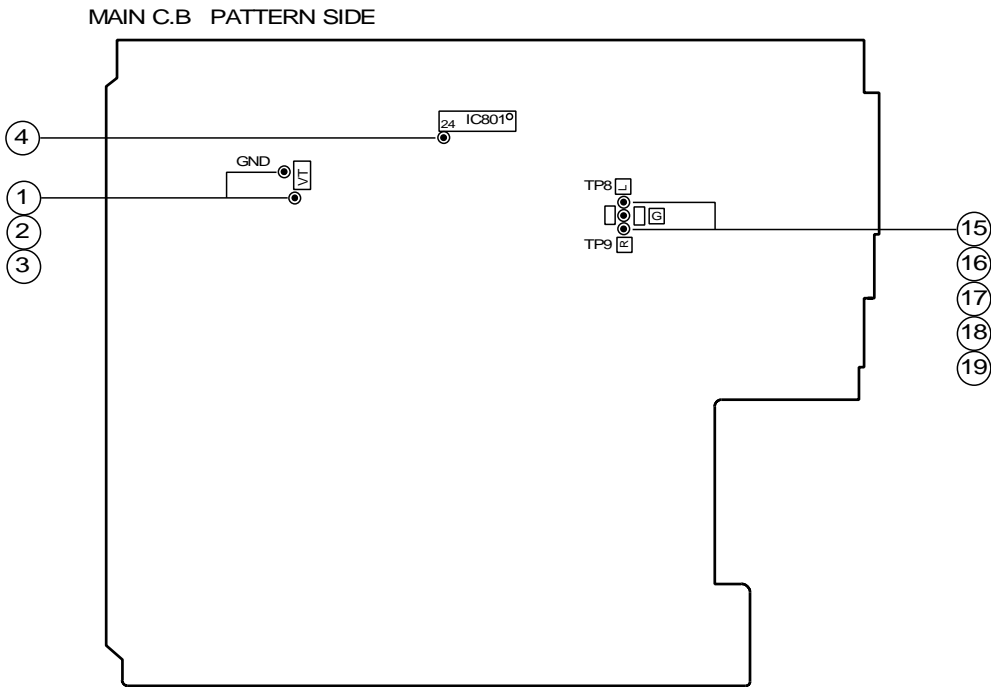
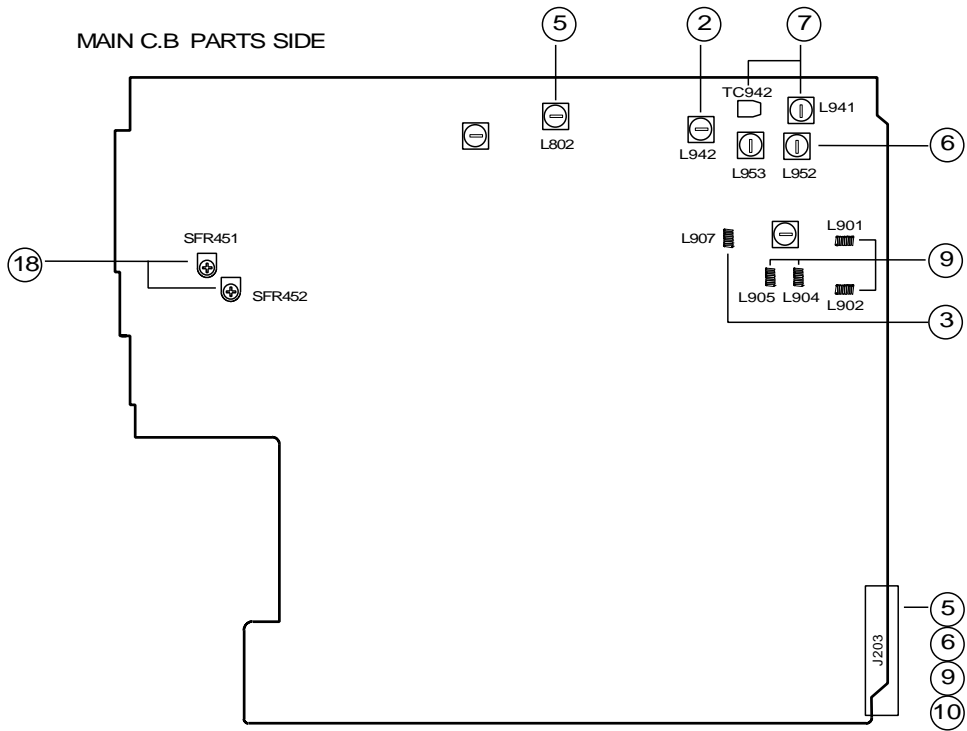

DECK C.B

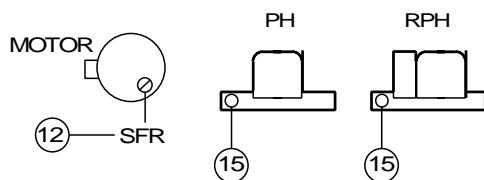

ELECTRICAL ADJUSTMENT -2/7

<TUNER Adjustment>

1. VT Check (MW)

Requirements

- Measuring instrument: Digital multimeter

Test points: VT, GND

- 1) Connect the digital multimeter between VT and GND.
- 2) Set the function to MW, and tune the receiving frequency of the unit at 1,602 kHz.
- 3) Check that the digital multimeter ranges under 9 V.
- 4) Tune the receiving frequency of the unit at 531 kHz.
- 5) Check that the digital multimeter ranges above 0.5 V.

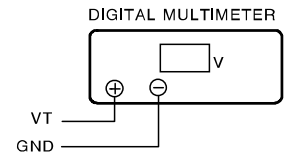

2. VT Adjustment (LW)

Requirements: Same as above.

- Adjustment point: L942

- 1) Connect the digital multimeter between VT and GND.
- 2) Set the function to FM, and tune the receiving frequency of the unit at 144.0 kHz.
- 3) Adjust L942 so that the digital multimeter ranges at 1.3 ± 0.05 V.

3. VT Adjustment and Check (FM)

Requirements: Same as the above.

- Adjustment point: L907

- 1) Connect the digital multimeter between VT and GND.
- 2) Set the function to FM, and tune the receiving frequency of the unit at 108.0 MHz.
- 3) Adjust L907 so that the digital multimeter ranges at 7.0 ± 0.1 V.
- 4) Tune the receiving frequency of the unit at 87.5 MHz.
- 5) Check that the digital multimeter ranges under 0.5 V.

4. CLOCK Check (MW)

Requirements

- Measuring instrument: Frequency counter

Test point: CLOCK (IC801 24PIN), GND

- 1) Connect the frequency counter between CLOCK and GND.
- 2) Set the function to MW, and tune the receiving frequency of the unit at 1,602 kHz.
- 3) Check that the frequency counter ranges at $2,160 \text{ kHz} \pm 45 \text{ Hz}$.

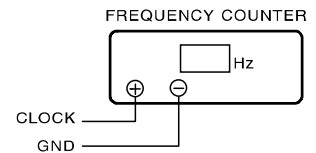

ELECTRICAL ADJUSTMENT -3/7

<MW/LW Adjustment>

Make the following preparations for MW/LW adjustment.

Preparations

- Standard Signal Generator (S.S.G.) / Loop antenna / Oscilloscope / Millivoltmeter / Dummy resistance (6 Ω)
 - 1) Connect the unit and measuring instruments as shown in the diagram below.
 - 2) Position the loop antenna connected to S.S.G. and the one connected to the unit 60 cm apart.

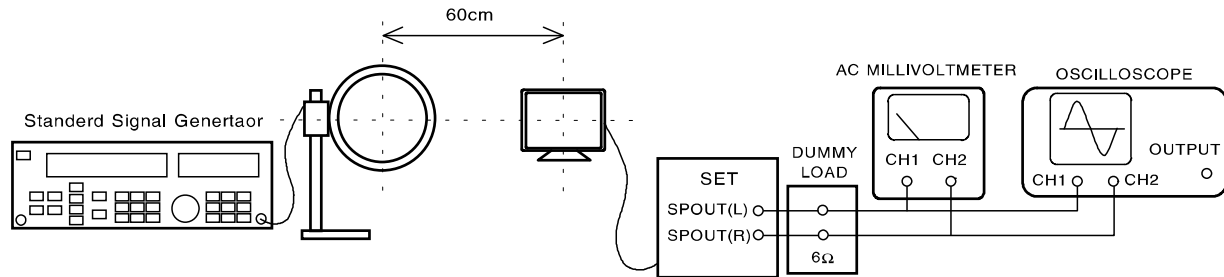

5. IF Adjustment (MW)

Requirements: As instructed in preparations.

- Adjustment point: L802
 - 1) Set S.S.G. to MW; carrier of 999 kHz with 30% modulation, and source at 1 kHz, position output at maximum.
 - 2) Tune the receiving frequency of the unit at MW 999 kHz.
 - 3) While monitoring the waveform at 1 kHz through the oscilloscope, lower the output level of S.S.G. maximum (till a certain degree of noise is monitored).
 - 4) Adjust L802 so that the millivoltmeter points maximum.

6. Tracking Adjustment (MW)

Requirements: As instructed in preparations.

- Adjustment point: L952 / L953
 - 1) Set S.S.G. to MW; carrier of 999 kHz with 30% modulation, and source at 1 kHz, position output at maximum.
 - 2) Tune the receiving frequency of the unit at MW 999 kHz.
 - 3) While monitoring the waveform at 1kHz through the oscilloscope, lower the output level of S.S.G. maximum (till a certain degree of noise is monitored).
 - 4) Adjust L952 so that the millivoltmeter points maximum.
 - 5) Set S.S.G. to MW; carrier of 603 kHz with 30% modulation, and source at 1 kHz.
 - 6) Tune the receiving frequency of the unit at MW 603 kHz.
 - 7) Adjust L953 so that the millivoltmeter points maximum.
 - 8) Repeat above steps 1) to 7) 2 to 3 times.

7. Tracking Adjustment(LW)

Requirements: As instructed in preparations.

- Adjustment point: L941/TC942
 - 1) Set S.S.G. to LW; carrier of 144 kHz with 30% modulation, and source at 1 kHz, position output at maximum.
 - 2) Tune the receiving frequency of the unit at LW144 kHz.
 - 3) While monitoring the waveform at 1kHz through the oscilloscope, lower the output level of S.S.G. maximum (till a certain degree of noise is monitored).
 - 4) Adjust L941 so that the millivoltmeter points maximum.
 - 5) Set S.S.G. to LW; carrier of 290 kHz with 30% modulation, and source at 1 kHz.
 - 6) Tune the receiving frequency of the unit at LW 290 kHz.
 - 7) Adjust TC942 so that the millivoltmeter points maximum.
 - 8) Repeat above steps 1) to 7) 2 to 3 times.

8. Auto-Stop Check (MW)

Requirements: As instructed in preparations.

- 1) Set S.S.G. to MW; carrier of 999 kHz with 30% modulation, source at 1 kHz, and output of 40 to 65 dBuV.
- 2) Apply the tuning search function, and check that the unit automatically stops at MW 999 kHz.

ELECTRICAL ADJUSTMENT -4/7

<FM Adjustment>

Make the following preparations for FM adjustment.

Preparations

- Standard Signal Generator (S.S.G.) / Loop antenna / Oscilloscope / Millivoltmeter / Dummy resistance (6 Ω)
 - 1) Connect the unit and measuring instruments as shown in the diagram below.
 - 2) Connect the output of S.S.G. to the antenna input of the unit.

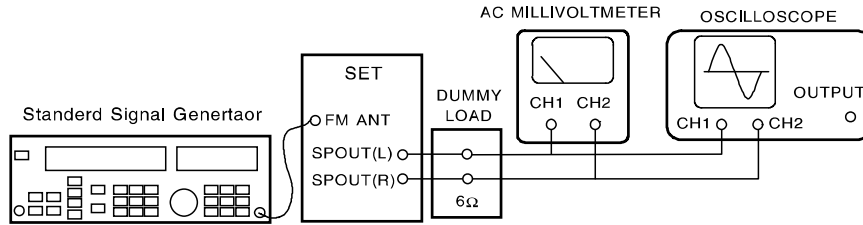

9. Tracking Adjustment

Requirements: As instructed in preparations.

- Adjustment point: L901/L902/L904/L905
 - 1) Set S.S.G. to FM; carrier of 108 MHz with 75 kHz modulation, and source at 1 kHz, position output at maximum.
 - 2) Tune the receiving frequency of the unit at FM 108 MHz.
 - 3) While monitoring the waveform at 1kHz through the oscilloscope, lower the output level of S.S.G. maximum (till a certain degree of noise is monitored).
 - 4) Adjust L901/L902/L904/L905 so that the millivoltmeter points maximum.

10. Separation Check

Requirements: As instructed in preparations.

- 1) Set S.S.G. to FM; carrier of 98 MHz with 67.5 kHz modulation, source at 1 kHz, and output at 74 dBuV.
- 2) Switch S.S.G. to PILOT ON, and set PILOT at 7.5 kHz.
- 3) Tune the receiving frequency of the unit at FM 98 MHz.
- 4) Allow the output of S.S.G. only from Lch, and check that the difference between Lch and Rch is 25 dB or above.
- 5) Apply the above check to Rch.

11. Auto-Stop Check

Requirements: As instructed in preparations.

- 1) Set S.S.G. to FM; carrier of 98 MHz with 75 kHz modulation, source at 1kHz, and output at 10 to 35 dBuV or less.
- 2) Apply the tuning search function, and check that the unit automatically stops at FM 98 MHz.

ELECTRICAL ADJUSTMENT -5/7

<DECK Section>

12. Tape Speed Adjustment (DECK 2)

Requirements

- Measuring instrument: Wow and flutter meter (frequency counter)

Test tape: TTA-100 (3 kHz)

Test point: HP OUT

Adjustment point: DECK MOTOR SFR

- 1) Connect the wow and flutter meter to HP OUT of the unit.
- 2) Insert the test tape (TTA-100) to DECK 2. Play back the middle part of the tape, and adjust DECK MOTOR SFR so that the level $3,000 \text{ Hz} \pm 45 \text{ Hz}$ is monitored.

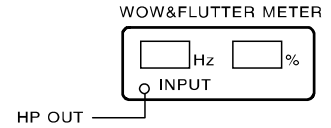

13. Tape Speed Check (DECK 1)

Requirements: Same as the above, 10.

- 1) Insert the test tape (TTA-100) to DECK 1. Play back the middle part of the tape, and check that the level is ranged within $\pm 45 \text{ Hz}$ as compared to the speed monitored for DECK 2.

14. Wow and Flutter Check (DECK 1 and DECK 2)

Requirements: Same as the above, 10.

- 1) Connect the wow and flutter meter to HP OUT of the unit.
- 2) Set the wow and flutter to JIS for INDICATOR and to W RMS (WTD) for mode.
- 3) Play back the middle part of the test tape (TTA-100), and check that the level ranges under 0.25%.

15. Head Azimuth Adjustment (DECK 1 and DECK 2)

Requirements

- Measuring instrument: Oscilloscope

Test tape: TTA-300 (10 kHz)

Test point: TP8 (Lch), TP9 (Rch)

Adjustment point: Head azimuth adjustment screw

- 1) Connect the probe CH1 of the oscilloscope to TP8 (Lch) and CH2 to TP9 (Rch).
- 2) Set V mode of the oscilloscope to ADD.
- 3) Insert the test tape (TTA-300) to DECK 1. Forward and play back the middle part of the tape, and adjust the head azimuth adjustment screw so that the waveform achieves its maximum level when 10 kHz is played.
- 4) After adjustment, secure the screw with glue (1600 B).
- 5) Apply the above steps 3) and 4) to DECK 2.

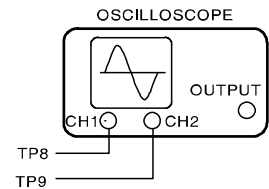

16. Playback Frequency Check (DECK 1 and DECK 2)

Requirements

- Measuring instrument: Millivoltmeter

Test tape: TTA-300 (315 Hz / 10 kHz)

Test point: TP8 (Lch), TP9 (Rch)

- 1) Connect CH1 of the millivoltmeter to TP8 (Lch) and CH2 to TP9 (Rch).
- 2) Insert the test tape (TTA-300) to DECK 1, and play back 315 Hz and 10 kHz.
- 3) Check that the level of 10 kHz is ranged within $\pm 3 \text{ dB}$ compared to the output level of 315 Hz as a reference.
- 4) Apply the above steps 2) and 3) to DECK 2.

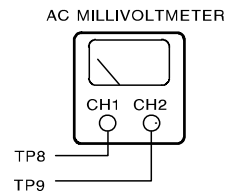

ELECTRICAL ADJUSTMENT -6/7

17. Playback Sensitivity Check (DECK 1 and DECK 2)

Requirements

- Measuring instrument: Millivoltmeter
- Test tape: TTA-200 (400 kHz)
- Test points: TP8 (Lch), TP9 (Rch)
- 1) Connect CH1 of the millivoltmeter to TP8 (Lch) and CH2 to TP9 (Rch).
- 2) Insert the test tape (TTA-200) to DECK 1 and play back.
- 3) Check that the output level is ranged within $110 \text{ mV} \pm 3 \text{ dB}$.
- 4) Apply the above steps, 2) and 3) to DECK 2.

18. Record/Playback Frequency Response Adjustment (DECK 2)

Requirements

- Measuring instrument: Millivoltmeter, Audio signal oscillator (low frequency oscillator), Attenuator

Test tape: TTA-602 (NORMAL)

Test points: TP8 (Lch), TP9 (Rch)

Input point: AUX (1 kHz / 8 kHz)

Adjustment points: SFR451 (Lch), SFR452 (Rch)

- 1) Connect CH1 of the millivoltmeter to TP8 (Lch) and CH2 to TP9 (Rch).
- 2) Connect the output of the oscillator to the attenuator, and then the attenuator to AUX of the unit.
- 3) Insert the test tape (TTA-602) to DECK 2, and record 1 kHz signal from AUX.
- 4) Adjust the attenuator so that the output levels at TP8 and TP9 are ranged at 10mV.
- 5) Record 1 kHz and 8 kHz alternatively.
- 6) Play back the tape. Adjust SFR451 (Lch)/SFR452 (Rch) so that the playback output level of 8kHz is ranged within $0 \pm 1 \text{ dB}$ compared to the playback output level of 1 kHz as reference.

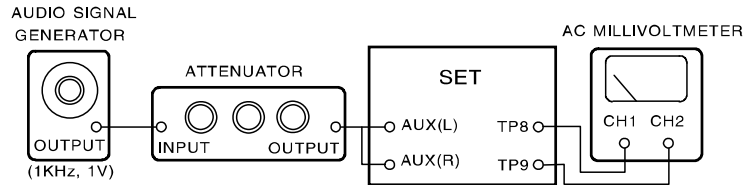

19. Record/Playback Sensitivity Check (DECK 2)

Requirements

- Measuring instrument: Same as the above, 16
- Test tape: TTA-602 (NORMAL)
- Test point: TP8 (Lch), TP9 (Rch)
- Input point: AUX (10 kHz)
- 1) Insert the test tape (TTA-602) to DECK 2, and record 1 kHz signal from AUX.
- 2) Adjust the attenuator so that the output levels at TP8 and TP9 are 100 mV.
- 3) Play back 1kHz, and check that the output level is ranged within $0 \text{ dB} \pm 2.5 \text{ dB}$ compared to the recording output level.

ELECTRICAL ADJUSTMENT -7/7

<FRONT Section>

FRONT C.B PATTERN SIDE

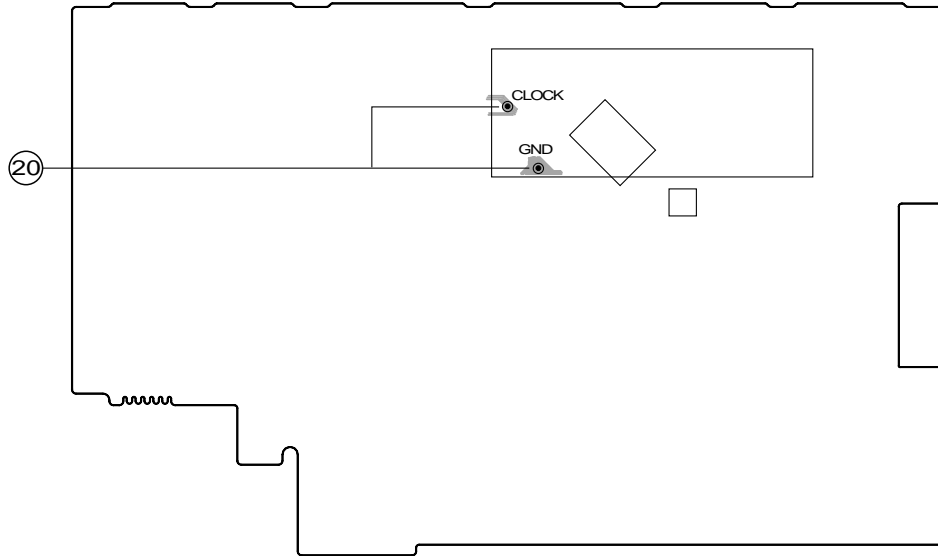

FRONT C.B PARTS SIDE

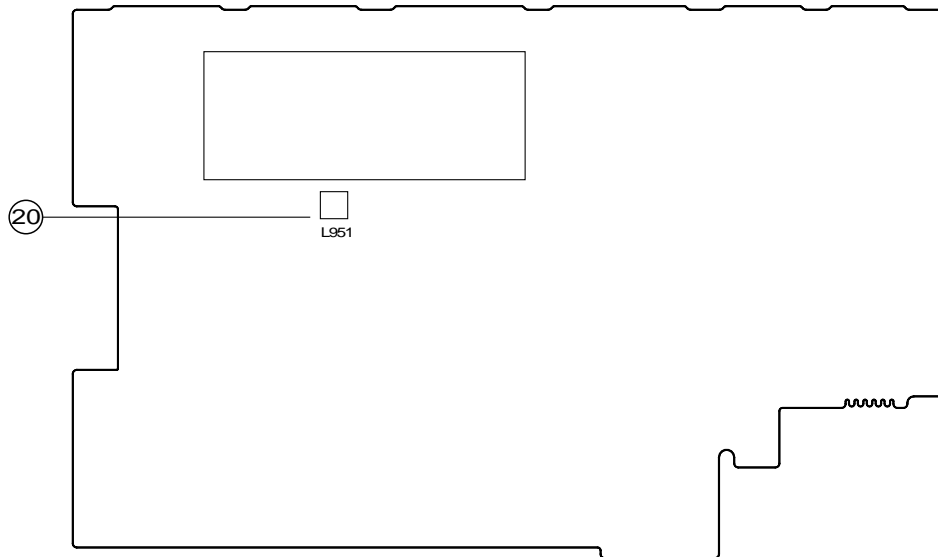

20. Clock Adjustment

Requirements

- Measuring instrument: Frequency counter

Test point: CLOCK, GND

Adjustment point: L951

- 1) While pressing the UP and POWER button, insert the AC plug to the outlet.
- 2) Adjust L951 so that the frequency counter indicates the frequency level within 72.743 ± 0.073 Hz.

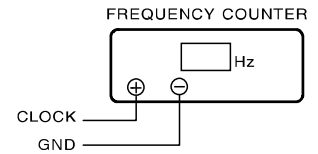

CD TEST MODE-1/1

1. How to Start the CD Test Mode

While pressing the CD OPEN/CLOSE button, insert the AC plug to the power outlet.
When the test mode is started, the message [TEST] is displayed.

2. How to Exit the CD Test Mode

Press the POWER button, push other FUNCTION button or disconnect the AC plug.
* Pressing any other function key during PLAY, aborts the test mode.

3. Function Descriptions and Application of the CD Test Mode

No	Mode	Operation	Display	Function	Checking item
1	Start mode		All indicators light	<ul style="list-style-type: none"> All FL indicators light 	<ul style="list-style-type: none"> FL check Microprocessor check
2	Search mode	STOP button	READING	<ul style="list-style-type: none"> LD illuminates all the time Focus search continuous operations *1,*2 Spindle motor continuous kick 	<ul style="list-style-type: none"> APC circuit check Laser current measurement Focus search waveform check Focus error waveform check (DRF in the search mode is ignored)
3	Play mode	Play button	Normal	<ul style="list-style-type: none"> Normal playback If TOC cannot be read, focus search is continued 	<ul style="list-style-type: none"> Each servo circuit is checked DRF check RF WAVE check(About 1.7vp-p)
4	Traverse mode	PAUSE button	Normal	<ul style="list-style-type: none"> Tracking servo OFF/ON Each time PAUSE button is pressed, the tracking servo repeats turning OFF/ON 	<ul style="list-style-type: none"> Tracking balance check
5	Sled mode	FF button	TEST	<ul style="list-style-type: none"> Pickup moves to the inner circumference *3 At the same time, lens kicks to the inner circumference 	<ul style="list-style-type: none"> Sled circuit check Tracking circuit check Mechanism operation check Pickup check
		RWD button	TEST	<ul style="list-style-type: none"> Pickup moves to the outer circumference *3 At the same time, lens kicks to the outer circumference 	
6	Spindle mode	REC/REC MUTE button	All indicators light	<ul style="list-style-type: none"> The spindle motor rotates forward (rough speed) by pressing the button and rotates backward by pressing one more time and stops by pressing again 	<ul style="list-style-type: none"> Spindle circuit Spindle motor

*1: The driver IC heats up and the protection circuit starts working when the focus search is continued for 10 minutes or longer.
There can be a case that operations can not be performed correctly.
In such a case, turn off the main power. After cooling down the machine, restart the machine.

*2: After the focus search is executed three times, the gain is changed to the CD-RW gain from the fourth time.

*3: Be careful not to damage the gear because the sled motor rotates while the FF or RWD button is being pressed even if the pick-up is located in the innermost track or the outermost track.

LCD DISPLAY-1/1

GRID ASSIGNMENT

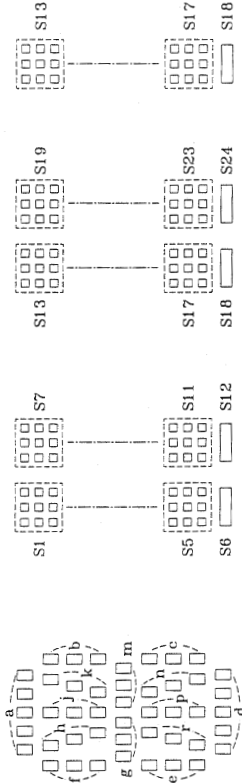
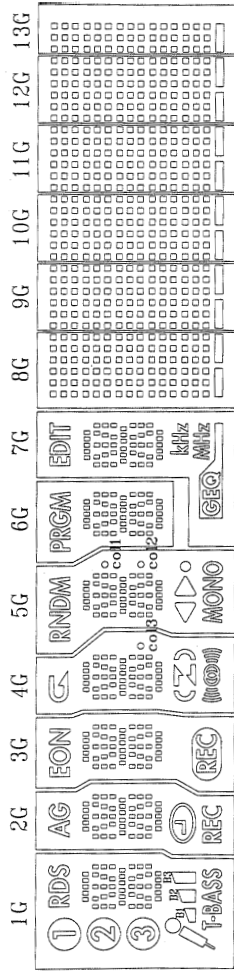

(1G - 7G)

(8G, 10G, 12G)

(9G, 11G)

(13G)

ANODE CONNECTION

	1G	2G	3G	4G	5G	6G	7G	8G	9G	10G	11G	12G	13G
P1	RDS	AG	EON	G	RNDM	PRGM	EDIT	S1	—	S1	—	S1	—
P2	h	h	h	h	h	h	a	S7	—	S7	—	S7	—
P3	h	h	h	h	h	h	a	S7	—	S7	—	S7	—
P4	j	j	j	j	j	j	h	—	S13	—	S13	—	S13
P5	k	k	k	k	k	k	j	—	S19	—	S19	—	—
P6	b	b	b	b	b	b	k	—	S2	—	S2	—	—
P7	f	f	f	f	f	f	b	—	S8	—	S8	—	—
P8	m	m	m	m	m	m	f	—	S14	—	S14	—	S14
P9	g	g	g	g	g	g	m	—	S20	—	S20	—	—
P10	c	c	c	c	c	c	m	—	S3	—	S3	—	—
P11	e	e	e	e	e	e	g	—	S9	—	S9	—	—
P12	r	r	r	r	r	r	e	—	S15	—	S15	—	S15
P13	p	p	p	p	p	p	e	—	S21	—	S21	—	—
P14	n	n	n	n	n	n	r	—	S4	—	S4	—	—
P15	d	d	d	d	d	d	p	—	S10	—	S10	—	—
P16	①	①	①	col3	col1	col1	p	—	—	—	—	—	—
P17	②	REC	REC	col3	col2	col2	d	—	S16	—	S16	—	S16
P18	③	—	—	col3	col2	col2	d	—	S22	—	S22	—	—
P19	—	—	—	col3	col2	col2	o	—	S5	—	S5	—	—
P20	T-BASS	—	—	col3	col2	col2	o	—	S11	—	S11	—	S11
P21	B1	—	—	col3	col2	col2	o	—	—	—	—	—	—
P22	B2	—	—	col3	col2	col2	o	—	S6	—	S6	—	—
P23	B3	—	—	col3	col2	col2	o	—	S12	—	S12	—	S12
P24	—	—	—	col3	col2	col2	o	—	—	—	—	—	—

PIN CONNECTION

PIN NO.	45	44	43	42	41	40	39	38	37	36	35	34	33	32	31	30	29	28	27	26	25	24	23	22	21	20	19	18	17	16	15	14	13	12	11
CONNECTION	F2	F2	NP	NP	P24	P23	P22	P21	P20	P19	P18	P17	P16	P15	P14	P13	P12	P11	P10	P9	P8	P7	P6	P5	P4	P3	P2	P1	1G	2G	3G	4G	5G	6G	7G

Notes

- 1) F1, F2 : Filament pin
- 2) nG : Grid pin
- 3) Pn : Anode pin
- 4) NP : No pin

10	9	8	7	6	5	4	3	2	1
8G	9G	10G	11G	12G	13G	NP	NP	F1	F1

IC BLOCK DIAGRAM -1/3

IC, BD3881FV

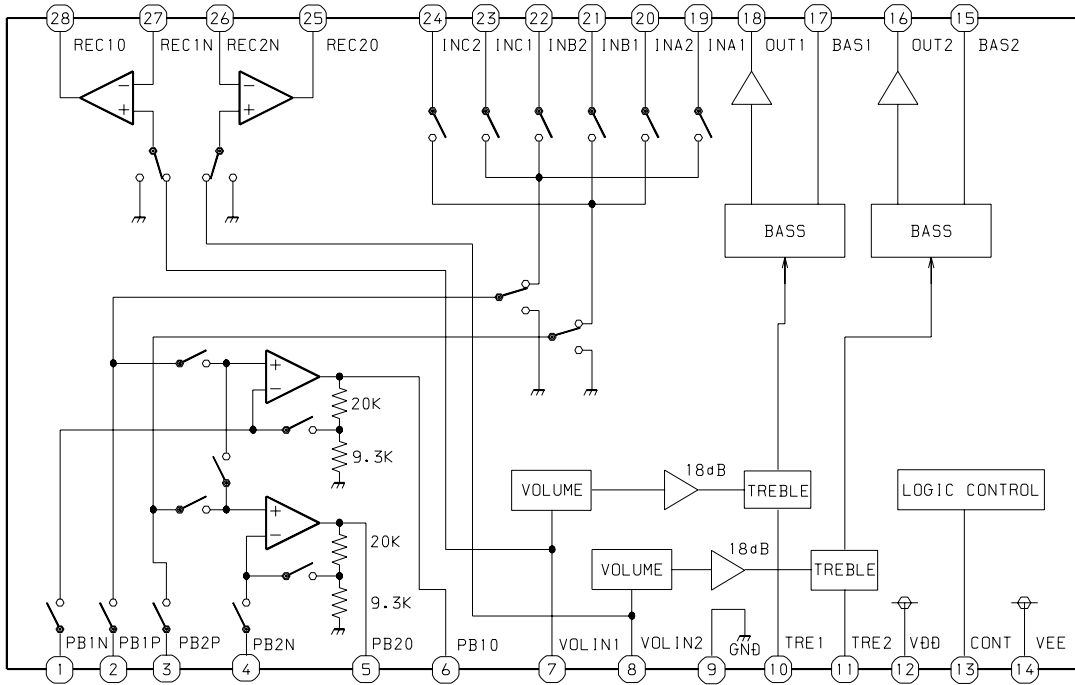

IC, NJM7806FA

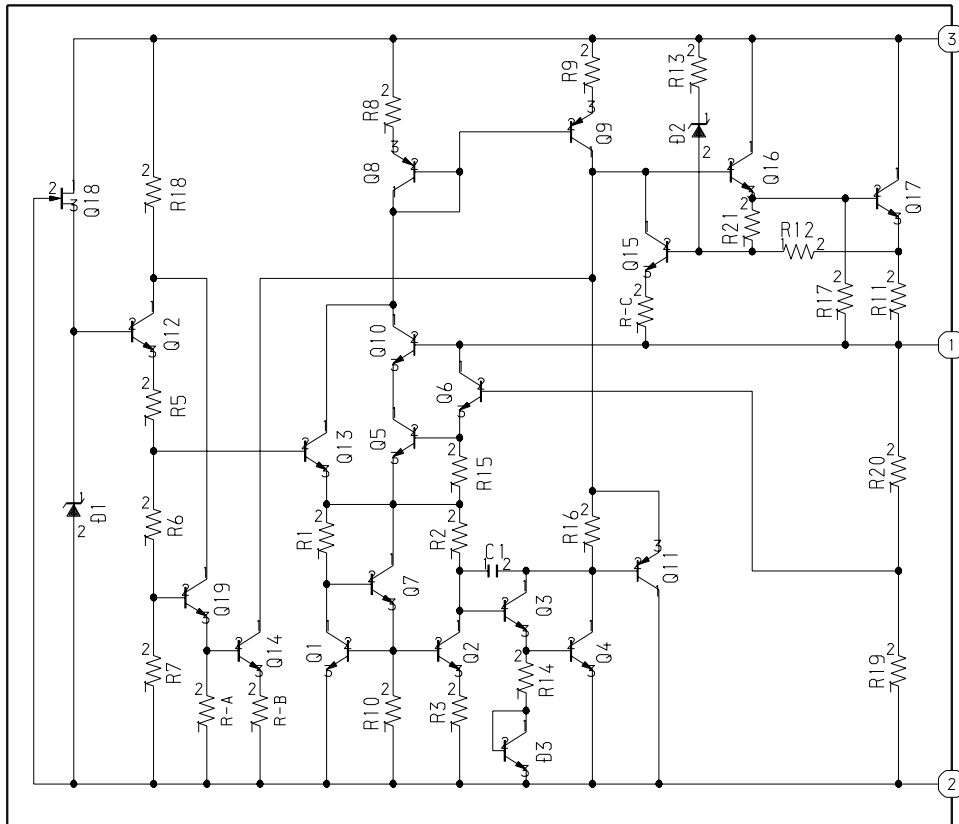

IC BLOCK DIAGRAM -1/3

IC, LA1845N-A

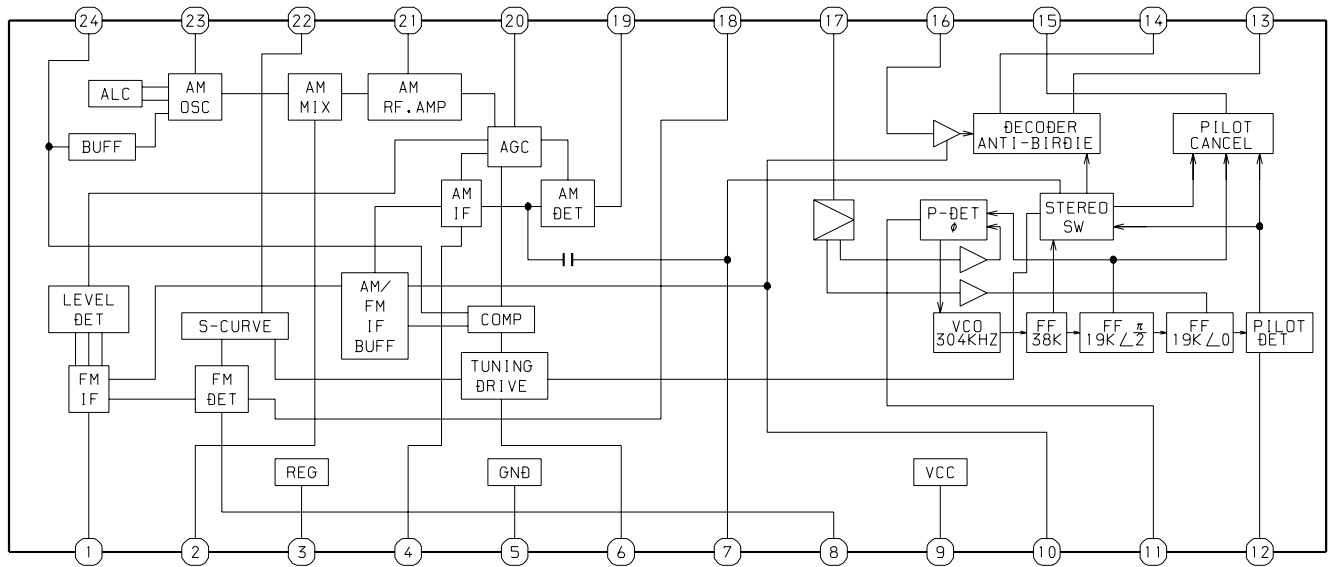

IC, LC7213D-N

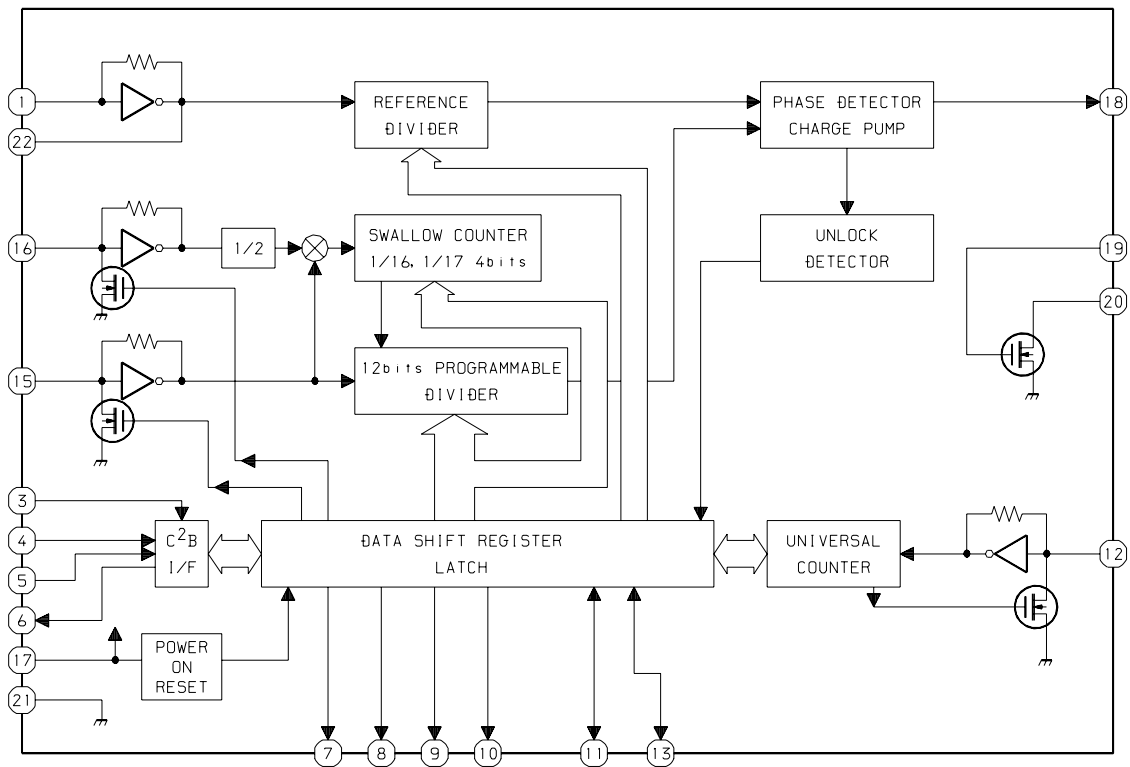

IC BLOCK DIAGRAM -3/3

IC, BU1920FS

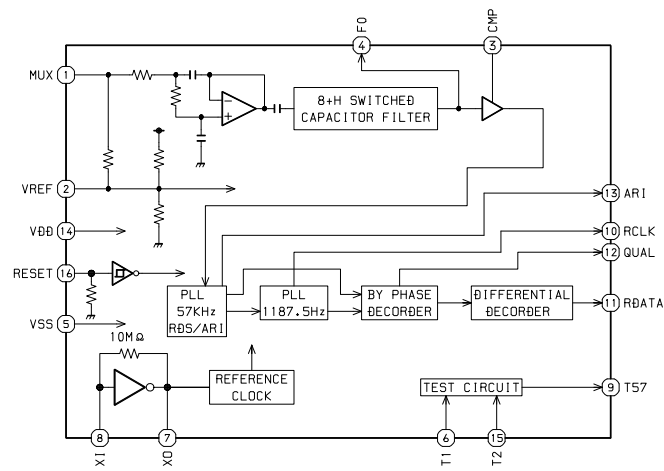

IC DESCRIPTION -1/1(μPD780226GF-033-3BA/μPD780228GF-089-3BA)-1/2

Pin No.	Pin Name	I/O	Description
1	O-MOTOR	O	DECK motor output.
2	O-SOL1	O	DECK1 solenoid output.
3	O-SOL2	O	DECK2 solenoid output.
4	O-STBY LED	O	Standby LED output.
5	O-MUTE	O	System mute ON/OFF output.
6	O-KSCAN	O	Key scan timing output.
7	O-PLL_CE	O	PLL chip enable output for LC72131D-N.
8	I-TM_BASE	I	Time-base signal input.
9	O-TU-ON	O	Tuner ON/OFF output.
10	O-PB2	O	DECK2 play back ON/OFF output.
11	O-VF	ñ	Not used.
12	I-AUTO1	I	DECK1 detecting reel rotation switch input.
13	I-REA	I	DECK2 prevention for mistaken recording switch input.
14	I-CST1	I	DECK1 cassette detect switch input.
15	I-CST2	I	DECK2 cassette detect switch input.
16	I-AUTO2	I	DECK2 detecting reel rotation switch input.
17	IC	ñ	GND.
18	VSS0	ñ	GND.
19	VDD0	ñ	Power supply input.
20	O-POWER	O	System power supply ON/OFF output.
21	I-JOG_A	I	JOG rotary encoder signal input (A/D).
22	I-JOG_B	I	JOG rotary encoder signal input (A/D).
23	I-VOL_A	I	VOL rotary encoder signal input (A/D).
24	I-VOL_B	I	VOL rotary encoder signal input (A/D).
25	I-SUBQ	I	CD SUBQ serial input.
26	I-WRQ	I	CD IC control input.
27	I-DRF	I	CD IC control input.
28	I-RDS_CLK	I	Tuner RDS clock output for BU1920FS. (Connected to GND through a resistor)
29	I-RDS_DATA	I	Tuner RDS data output for BU1920FS. (Connected to GND through a resistor)
30	RESET	I	Reset input.
31	O-DSC/O-DATA	O	Serial data latch output for BD3881FV / PLL data output for LC72131D-N.
32	O-CLK_SFT	O	MICON clock shift output.
33	I-IFC	I	Tune IF count serial data input.
34	I-RMC	I	System remote control signal input.
35	I-DISH	I	CD turntable photo sensor signal input.
36	I-STEREO	I	Tuner stereo detected input.
37	VDD1	ñ	Power supply input.
38	X2	ñ	4.19MHz oscillator circuit.
39	X1	ñ	4.19MHz oscillator circuit.
40	VSS	ñ	GND.
41	AVDD	ñ	Power supply input.
42	I-HOLD	I	Power failure detected input "L" to stop clock and hold memory.
43	I-CDSW	I	CD mechanical switch A/D converter input.

IC DESCRIPTION -1/1(μPD780226GF-033-3BA/μPD780228GF-089-3BA)-2/2

Pin No.	Pin Name	I/O	Description
44	I-SPEANA_1	I	A/D input for spectrum analyser level display.
45	I-SPEANA_2	I	A/D input for spectrum analyser level display.
46	I-SPEANA_3	I	A/D input for spectrum analyser level display.
47	I-KEY 1	I	Key A/D input 1.
48	I-KEY 2	I	Key A/D input 2.
49	I-TU_SIG	I	Tuner RDS signal input. (Connected to GND through a resistor)
50	AVSS	ñ	GND.
51	O-BIAS	O	Bias output.
52	O-CD_CE	O	CD chip enable output.
53	O-CD_CLK	O	CD serial clock output.
54	O-CD_DATA	O	CD serial data output.
55	O-CLK	O	PLL clock output for LC72131D-N.
56 ~ 59	NC	ñ	Not connected.
60	I-CAM2	I	DECK2 cam switch input.
61	I-CAM1	I	DECK1 cam switch input.
62 ~ 70	P24 ~ P16	O	FL segment P24 ~ P16 output.
71	P15/AM 10K	O/I	FL segment P15 output / AM 10K data input to diode.
72	P14/KARAOKE	O/I	FL segment P14 output / KARAOKE data input to diode (LH only).
73	P13/LW	O/I	FL segment P13 output / LW data input to diode (not used).
74	P12/SW	O/I	FL segment P12 output / SW data input to diode (not used).
75	P11/OIRT	O/I	FL segment P11 output / OIRT data input to diode (not used).
76	P10/FM WIDE	O/I	FL segment P10 output / FM WIDE data input to diode (not used).
77	P9/R+1	O/I	FL segment P9 output / R+1 data input to diode (not used).
78	P8/DEMO	O/I	FL segment P8 output / DEMO data input to diode (not used).
79	VDD2	ñ	Power supply input.
80	VLOAD	_	Power supply for FL display.
81	P7/ECO-OFF	O/I	FL segment P7 output / ECO-OFF data input to diode (not used).
82 ~ 87	P6 ~ P1	O	FL segment P6 ~ P1 output.
88 ~ 100	G1 ~ G13	O	FL grid G1 ~ G13 output.

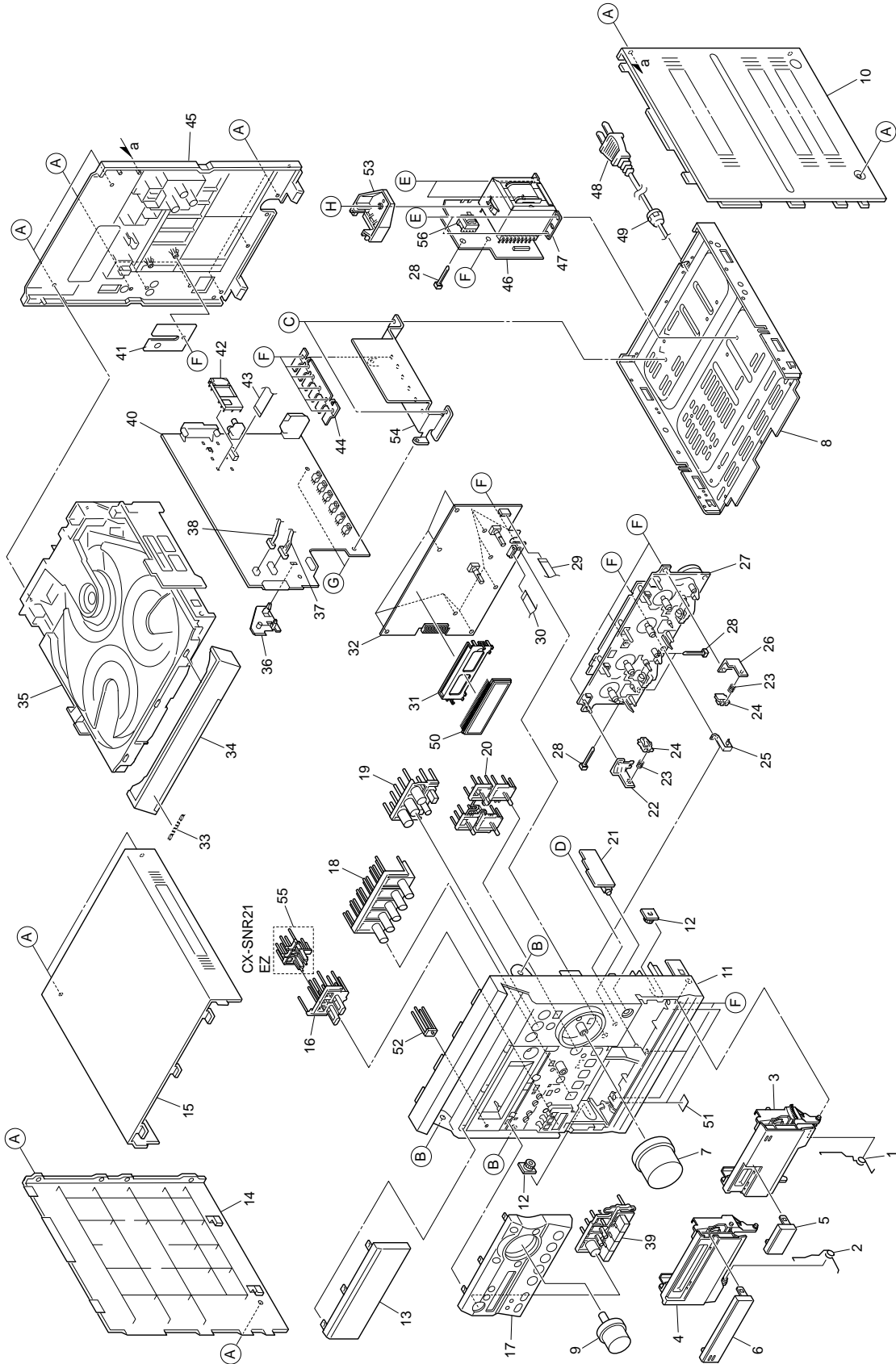

MECHANICAL, MECHANISM PARTS LIST -1/1

! = Δ SAFTY PARTS
 C = Components marked

All components used on this model at the production line are shown in this service manual.

However, please note that not all components will be available as spare parts for after-sales service.

Components marked S and O are designated as spare parts for service and will be stocked at the spare parts centers.

Components marked X and R are not designated as spare parts for after sales service, and will not be stocked at the spare parts centers.

UNIT-NAME	! C	REF-NO	PARTS-NO	PARTS-NAME	SUFFIX&MODEL		
					CX-SNR21 EZSC1	CX-SNR20 KSC1	
	O	MC1001	8A-NF8-282-010	SPR-T, EJECT 2	a	b	
	O	MC1002	8A-NF8-281-010	SPR-T, EJECT 1	a	b	
	O	MC1003	8C-NF9-005-010	BOX, CASS 2	a	b	
	O	MC1004	8C-NF9-004-010	BOX, CASS 1	a	b	
	O	MC1005	8C-NF8-006-010	WINDOW, CASS 2	a	b	
	O	MC1006	8C-NF8-005-010	WINDOW, CASS 1	a	b	
	O	MC1007	8C-NF9-001-010	KNOB, RTRY VOL	a	b	
	X	MC1008	8C-NF8-234-010	CHAS, MAIN CC 66-35	a	b	
	O	MC1009	8C-NF8-027-010	KNOB, RTRY JOG	a	b	
	O	MC1010	8C-NF8-030-010	PANEL, RIGHT NV	a	b	
	O	MC1011	8C-NF9-023-110	CABI, FR EZ	a	b	
	O	MC1012	8Z-NF6-210-010	DMPR, 150 N	a	b	
	O	MC1013	8C-NF9-009-110	WINDOW, DISP EZR	a	.	
	O	MC1013	8C-NF9-007-010	WINDOW, DISP H	.	b	
	O	MC1014	8C-NF8-021-010	PANEL, LEFT	a	b	
	O	MC1015	8C-NF8-023-110	PANEL, TOP	a	b	
	O	MC1016	8C-NF8-029-010	KEY, REC EZ	a	b	
	O	MC1017	8C-NF7-031-010	PANEL, FR EZR	a	.	
	O	MC1017	8C-NF8-028-010	PANEL, FR EZ	.	b	
	O	MC1018	8C-NF8-013-010	KEY, OPE	a	b	
					CX-SNR21 EZSC1	CX-SNR20 KSC1	
	O	MC1019	8C-NF8-010-010	KEY, CD	a	b	
	O	MC1020	8C-NF8-011-010	KEY, ENTER	a	b	
	X	MC1021	8C-NF9-646-110	PWB, HP EZ/K	a	b	
	O	MC1022	87-NF4-216-010	HLDR, LOCK 1	a	b	
	O	MC1023	86-NF9-224-010	SPR-C, LOCK	a	b	
	O	MC1024	82-NF5-229-010	PLATE, LOCK (*)	a	b	
	X	MC1025	8C-NF9-201-010	PLATE, EARTH MECHA	a	b	
	O	MC1026	87-NF4-217-110	HLDR, LOCK 2	a	b	
	X	MC1027	M8-CZK-292-170	CMAT6Z2 (1+1)ALPS	a	b	
	O	MC1028	87-A90-193-010	HLDR, CV100 (B)	a	b	
	O	MC1029	88-908-291-110	FF-CABLE, 8P 1.25 290MM	a	b	
	O	MC1030	88-911-101-110	FF-CABLE, 11P 1.25 100MM	a	b	
	O	MC1031	8A-NFA-208-010	GUIDE, FL 100-25 ANFA	a	b	
	X	MC1032	8C-NF9-621-010	PWB, FRONT CNF-9	a	b	
	O	MC1033	87-B00-002-010	BADGE, AIWA 30 ABS SIL	a	b	
	O	MC1034	8C-NF8-008-010	PANEL, TRAY	a	b	
	X	MC1035	M8-BZG-29J-070	BZG-2 ZD9GNC1	a	b	
	O	MC1036	8A-NF8-206-010	HLDR, PWB M	a	b	
	O	MC1037	8C-NF9-606-010	CONN ASSY, 8P -RPB	a	b	
	O	MC1038	8C-NF9-605-010	CONN ASSY, 3P -PB	a	b	
					CX-SNR21 EZSC1	CX-SNR20 KSC1	
	O	MC1039	8C-NF8-009-010	KEY, POWER	a	b	
	X	MC1040	8C-NF9-641-110	PWB, MAIN EZ/K	a	b	
	X	MC1041	8C-NF9-623-010	PWB, HLDR WIRE CNF-9	a	b	
	X	MC1042	8C-ZA3-618-010	SHLD-CASE, CZA-3 EZ S	a	b	
	O	MC1043	88-906-251-110	FF-CABLE, 6P 1.25	a	b	
	X	MC1044	8C-NF9-207-010	HLDR, TR C	a	b	
	O	MC1045	8C-NF9-014-010	CABI, REAR EZSC	a	.	
	O	MC1045	8C-NF9-013-010	CABI, REAR KSC	.	b	
	X	MC1046	8C-NF9-642-110	PWB, PT 66 EZ/K	a	b	
	!	MC1047	8C-NF9-603-010	PT, CNF-9 EZ	a	b	
	!	O	MC1048	87-A80-143-010	AC CORD ASSY, E BLK	a	b
	O	MC1049	87-085-185-010	BUSHING, AC CORD (E) CM-22B	a	b	
	O	MC1050	8C-NF9-615-010	FL, HUA-13SS09T	a	b	
	X	MC1051	8B-NF9-204-010	CUSH, 11-8.5-2	a	b	
	O	MC1052	8C-NF8-014-010	REFLECTOR, ECO	a	b	
	O	MC1053	8A-NF9-211-010	HLDR, PWB PT HI	a	b	
	X	MC1054	8C-NF9-206-010	HT-SINK, MAIN C EZ	a	b	
	O	MC1055	8C-NF7-009-010	KEY, RDS W/O AG	a	.	
	!	O	MC1056	8B-MA6-675-010	PT, SUB BMA E (VRK)	a	b
	O	MC1A	87-B10-091-010	UTT2+3-10 W/O SLOT BLK	a	b	
					CX-SNR21 EZSC1	CX-SNR20 KSC1	
	O	MC1B	87-721-096-410	QT2+3-10 W/O SLOT	a	b	
	O	MC1C	87-B10-315-010	BVIT3B+3-8 R W/O	a	b	
	O	MC1D	88-AR1-217-010	S-SCREW, BFT2+3-8	a	b	
	O	MC1E	87-078-200-010	S-SCREW, ITC+4-8 R	a	b	
	O	MC1F	87-067-703-010	BVT2+3-10 W/O SLOt	a	b	
	O	MC1G	87-NF4-224-010	S-SCREW, IT3B+3-8 CU	a	b	
	O	MC1H	87-067-689-010	BVTT+3-8	a	b	

COLOR NAME TABLE

Basic color symbol	Color	Basic color symbol	Color	Basic color symbol	Color
B	Black	C	Cream	D	Orange
G	Green	H	Gray	L	Blue
LT	Transparent Blue	N	Gold	P	Pink
R	Red	S	Silver	ST	Titan Silver
T	Brown	V	Violet	W	White
WT	Transparent White	Y	Yellow	YT	Transparent Yellow
LM	Metallic Blue	LL	Light Blue	GT	Transparent Green
LD	Dark Blue	DT	Transparent Orange	GM	Metallic Green
YM	Metallic Yellow	DM	Metallic Orange	PT	Transparent Pink
LA	Aqua Blue	GL	Light Green	HT	Transparent Gray
HM	Metallic Gray	NH	Champagne Gold	M	Wood Pattern

TAPE MECHANISM EXPLODED VIEW -1/1 <CMAT6Z2(1+1)ALPS>

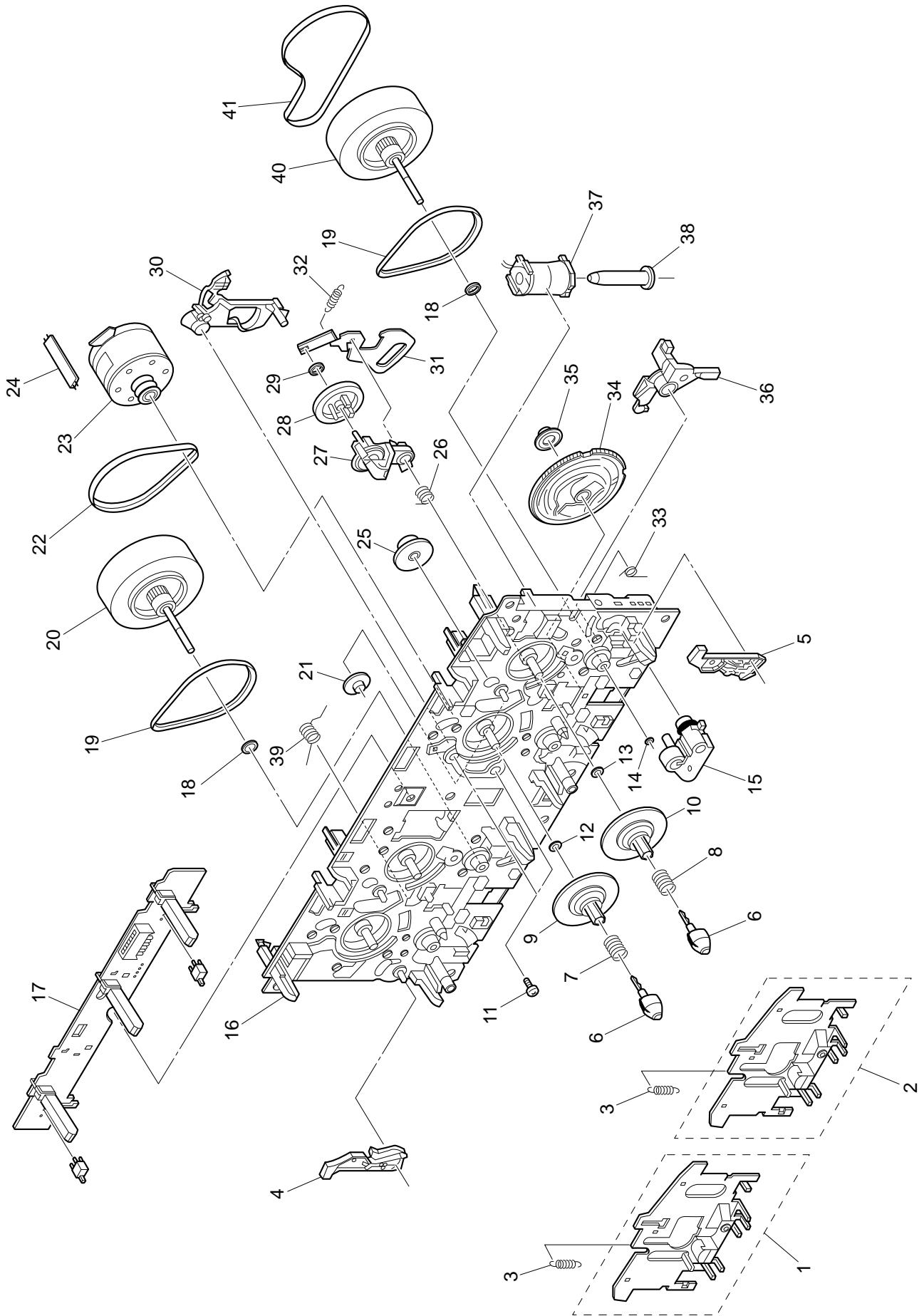

TAPE MECHANISM PARTS LIST -1/1 <CMAT6Z2(1+1)ALPS>

! = Δ SAFETY PARTS
 C = Components marked

All components used on this model at the production line are shown in this service manual.
 However, please note that not all components will be available as spare parts for after-sales service.
 Components marked S and O are designated as spare parts for service and will be stocked at the spare parts centers.
 Components marked X and R are not designated as spare parts for after sales service, and will not be stocked at the spare parts centers.

UNIT-NAME	! C	REF-NO	PARTS-NO	PARTS-NAME	SUFFIX&MODEL
CMAT6Z2 (1+1) ALPS					
	O	ST1001	SF-513-889-000	PLATE HD BLK	a
	O	ST1002	SF-513-888-000	PLATE HD BLK	a
	O	ST1003	SF-K32-T32-000	SPRING HB	a
	O	ST1004	SF-D58-H13-000	ARM INTERLOCK L	a
	O	ST1005	SF-D58-K13-000	ARM INTERLOCK R	a
	O	ST1006	SF-D53-M51-000	REEL FEATHER	a
	O	ST1007	SF-K32-U12-000	SP REEL (L)	a
	O	ST1008	SF-K32-V12-000	SP REEL (R)	a
	O	ST1009	SF-D56-GS3-000	REEL BASE	a
	O	ST1010	SF-D52-W51-000	REEL BASE	a
	O	ST1011	SF-G11-414-000	SCREW,PAN SW 2.6X5 ZN	a
	O	ST1012	SF-J11-131-000	PW,4.1X0.13	a
	O	ST1013	SF-J11-135-000	PW,4.1X0.25	a
	O	ST1014	SU-J16-F11-000	PW,1.75X0.4	a
	O	ST1015	SF-514-135-000	ROLLER PINCH R BLK	a
	O	ST1016	SF-612-252-000	CHASSIS BASE BLK	a
	O	ST1017	SF-567-700-000	PWB CONTROL BLK	a
	O	ST1018	SF-J11-130-000	PW,2.6X0.25	a
	O	ST1019	SF-F19-S31-000	F/R BELT	a
	O	ST1020	SF-R26-C11-000	ASSY F/W	a
CMAT6Z2 (1+1) ALPS					
	O	ST1021	SF-D53-K52-000	PLAY GEAR (A)	a
	O	ST1022	SF-F19-N22-000	MAIN BELT	a
	O	ST1023	SF-525-349-000	MTR MAIN BLK	a
	X	ST1024	SW-G58-H03-000	2 CORE JUMPER LEAD	a
	O	ST1025	SF-D60-L12-000	FF GEAR (E)	a
	O	ST1026	SF-K35-K14-000	CAM SP	a
	O	ST1027	SF-522-063-000	CLUTCH ASSY BLK	a
	O	ST1028	SF-D60-B15-000	PULLEY F/R	a
	O	ST1029	SF-J11-117-000	WASHER 1.7X0.25	a
	O	ST1030	SF-D58-T12-000	LEVER BRAKE	a
	O	ST1031	SF-C65-W21-000	LEVER F/R	a
	O	ST1032	SF-K35-E14-000	SP ARM F/R	a
	O	ST1033	SF-K32-R21-000	SP ARM PLAY	a
	O	ST1034	SF-D61-C14-000	CAM GEAR	a
	O	ST1035	SF-D59-F12-000	BUSH	a
	O	ST1036	SF-D58-P15-000	ARM PLAY	a
	O	ST1037	SF-765-295-000	SOLENOID BLK	a
	O	ST1038	SF-L41-S22-000	PLANGER	a
	O	ST1039	SF-K34-Y11-000	B/C SP	a
	O	ST1040	SF-R26-D11-000	ASSY F/W	a
CMAT6Z2 (1+1) ALPS					
	O	ST1041	SF-F19-N31-000	MAIN BELT	a

GENERAL SPEAKER DISASSEMBLY INSTRUCTIONS (FOR REFERENCE) -1/1

Type.1

Insert a flat-bladed screwdriver into the position indicated by the arrows and remove the panel. Remove the screws of each speaker unit and then remove the speaker units.

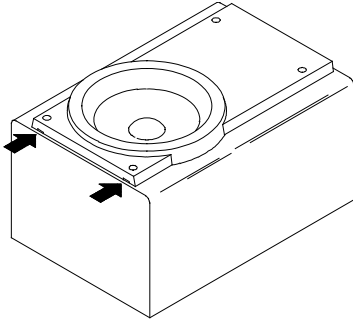

Type.2

Remove the grill frame and four pieces of rubber caps by pulling out with a flat-bladed screwdriver. Remove the screws from hole where installed rubber caps. Insert a flat-bladed screwdriver into the position indicated by the arrows and remove the panel. Remove the screws of each speaker unit and then remove the speaker units.

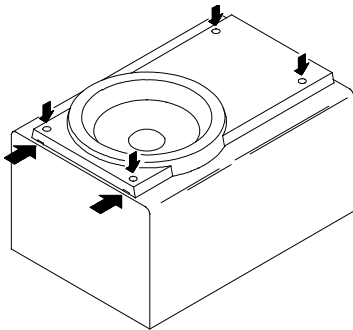

Type.3

Insert a flat-bladed screwdriver into the position indicated by the arrows and remove the panel. Turn the speaker unit to counter-clockwise direction while inserting a flat-bladed screwdriver into one of the hollows around speaker unit, and then remove the speaker unit. After replacing the speaker unit, install it turning to clockwise direction until "click" sound comes out.

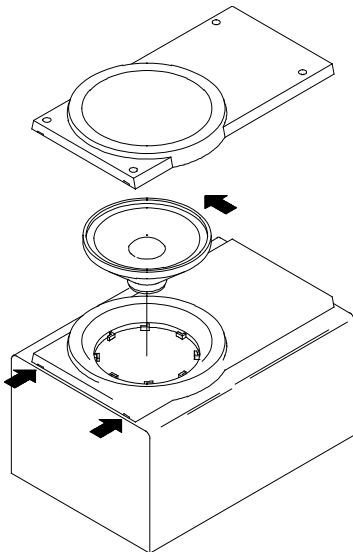

Type.4

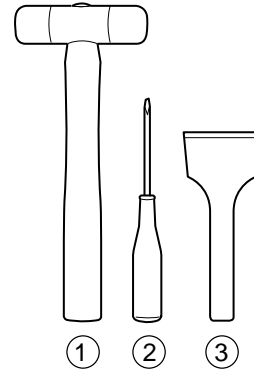

TOOLS

- ① Plastic head hammer
- ② ⊖ flat head screwdriver
- ③ Cut chisel

How to Remove the PANEL, FR

1. Insert the ⊖ flat head screwdriver tip into the gap between the PANEL, FR and the PANEL, SPKR. Tap the head of the ⊖ flat head screwdriver with the plastic hammer head, and create the clearance as shown in Fig-1.
2. Insert the cut chisel in the clearance, and tap the head of the cut chisel with plastic hammer as shown in Fig-2, to remove the PANEL, FR.
3. Place the speaker horizontally. Tap head of the cut chisel with plastic hammer as shown in Fig-3, and remove the PANEL, FR completely.

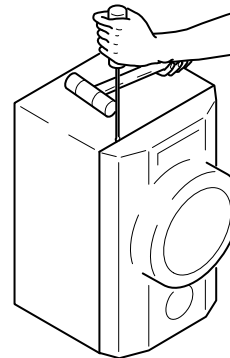

Fig-1

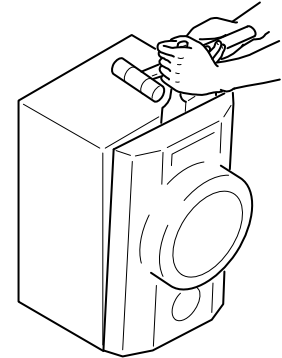

Fig-2

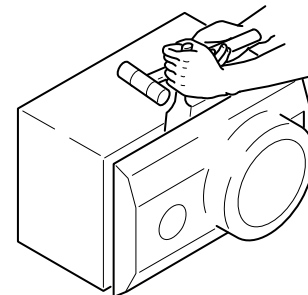

Fig-3

How to Attach the PANEL, FR

Attach the PANEL, FR to the PANEL, SPKR. Tap the four corners of the PANEL, FR with the plastic hammer to fit the PANEL, FR into the PANEL, SPKR completely.

SPEAKER PARTS LIST -1/1 <SX-NR20>

! = Δ SAFTY PARTS
 C = Components marked

All components used on this model at the production line are shown in this service manual.
 However, please note that not all components will be available as spare parts for after-sales service.
 Components marked S and O are designated as spare parts for service and will be stocked at the spare parts centers.
 Components marked X and R are not designated as spare parts for after sales service, and will not be stocked at the spare parts centers.

UNIT-NAME	! C	REF-NO	PARTS-NO	PARTS-NAME	SUFFIX&MODEL
					SX-SNR20
					YSN
	O	SP1001	88-NSK-610-010	SPKR, CERAMIC ASSY	a
	O	SP1002	8A-NSJ-006-010	BADGE, AIWA S35	a
	O	SP1003	8C-NS9-001-010	PANEL, FR L	a
	O	SP1004	8C-NS9-002-010	PANEL, FR R	a
	X	SP1005	8C-NS9-003-010	GRILLE, FRAME	a
	O	SP1006	8C-NS9-011-010	PANEL, DUCT	a
	O	SP1007	8C-NS9-013-010	ADAPTOR, W	a
	O	SP1008	8C-NS9-014-010	GRILLE, FRAME ASSY	a
	X	SP1009	8C-NS9-015-010	NET,	a
	O	SP1010	8C-NS9-018-010	CORD, SPKR S	a
	X	SP1011	8C-NS9-019-010	LBL, SPEC YS	a
	O	SP1012	8C-NS9-602-010	SPKR, CERAMIC ASSY 60	a
	O	SP1013	8C-NS9-606-010	SPKR, W 120/16	a
	X	SP1014	8Z-NS3-025-010	CORD, BUSH S	a
	X	SP1015	8C-NS9-853-010	CUSHION, ASSY SOZ	a
	X	SP1016	PC-NS9-963-070	SX-SNR20 YSN	a

OTHER PARTS LIST -1/1

- ! = Δ SAFTY PARTS
- C = Components marked

All components used on this model at the production line are shown in this service manual.
 However, please note that not all components will be available as spare parts for after-sales service.
 Components marked S and O are designated as spare parts for service and will be stocked at the spare parts centers.
 Components marked X and R are not designated as spare parts for after sales service, and will not be stocked at the spare parts centers.

UNIT-NAME	! C	REF-NO	PARTS-NO	PARTS-NAME	SUFFIX&MODEL	
					CX - SNR21	CX - SNR20
					EZSC1	KSC1
	X		8C-NF8-045-010	SH, FL	a	b
	X		8C-NF9-620-010	PWB, COMB FRONT CNF-9	a	b
	X		87-B40-281-010	LBL, BAR-CODE A 35X8	a	b
	X		87-057-995-010	LBL, CAUTION EFSD	a	b
	X		87-057-961-010	LBL, CAUTION TRIANGLE	a	b
	X		8C-NF9-640-110	PWB, COMB MAIN EZ/K	a	b



アイワ株式会社 〒110-8710 東京都台東区池之端1-2-11 ☎03(3827)3111 (代表)
AIWA CO.,LTD. 2-11, IKENOHATA 1-CHOME, TAITO-KU, TOKYO 110-8710, JAPAN TEL:03 (3827) 3111

0251431