

Service Manual

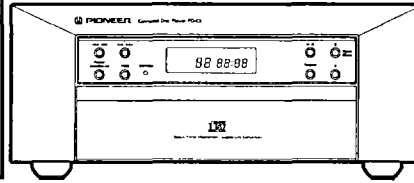

ORDER NO.
RRV1018

COMPACT DISC PLAYER

PD-C5

PD-C3

THIS MANUAL IS APPLICABLE TO THE FOLLOWING MODEL(S) AND TYPE(S).

Type	Model		Power Requirement	Remarks
	PD-C5	PD-C3		
KU	○	—	AC120V	
WE	○	○	AC220 - 240V	
WEWM	○	○	AC220 - 240V	
WB	○	○	AC220 - 240V	

- For the following : PD-C5/WE, WEWM and WB ; PD-C3/WE, WEWM and WB, refer to page 33 - 34.

CONTENTS

1. SAFETY INFORMATION	2
2. EXPLODED VIEWS, PACKING AND PARTS LIST	4
3. BLOCK DIAGRAM	11
4. SCHEMATIC DIAGRAM.....	12
5. PCB CONNECTION DIAGRAM.....	17
6. PCB PARTS LIST	21
7. ADJUSTMENTS	23
8. FL INFORMATION.....	32
9. FOR PD-C5/WEWM, WE, WB, PD-C3/WEWM, WE AND WB.....	33
10. PANEL FACILITIES.....	35
11. SPECIFICATIONS	36

1. SAFETY INFORMATION

This service manual is intended for qualified service technicians; it is not meant for the casual do-it-yourselfer. Qualified technicians have the necessary test equipment and tools, and have been trained to properly and safely repair complex products such as those covered by this manual. Improperly performed repairs can adversely affect the safety and reliability of the product and may void the warranty. If you are not qualified to perform the repair of this product properly and safely, you should not risk trying to do so and refer the repair to a qualified service technician.



WARNING

Lead in solder used in this product is listed by the California Health and Welfare agency as a known reproductive toxicant which may cause birth defects or other reproductive harm (California Health & Safety Code, Section 25249.5).

When servicing or handling circuit boards and other components which contain lead in solder, avoid unprotected skin contact with the solder. Also, when soldering do not inhale any smoke or fumes produced.



NOTICE

(FOR CANADIAN MODEL ONLY)

Fuse symbols  (fast operating fuse) and/or  (slow operating fuse) on PCB indicate that replacement parts must be of identical designation.

REMARQUE

(POUR MODÈLE CANADIEN SEULEMENT)

Les symboles de fusible  (fusible de type rapide) et/ou  (fusible de type lent) sur CCI indiquent que les pièces de remplacement doivent avoir la même désignation.

(FOR USA MODEL ONLY)

1. SAFETY PRECAUTIONS

The following check should be performed for the continued protection of the customer and service technician.

LEAKAGE CURRENT CHECK

Measure leakage current to a known earth ground (water pipe, conduit, etc.) by connecting a leakage current tester such as Simpson Model 229-2 or equivalent between the earth ground and all exposed metal parts of the appliance (input/output terminals, screwheads, metal overlays, control shaft, etc.). Plug the AC line cord of the appliance directly into a 120V AC 60Hz outlet and turn the AC power switch on. Any current measured must not exceed 0.5mA.

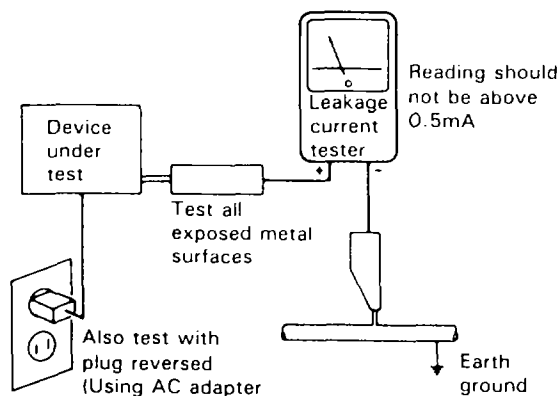

AC Leakage Test

ANY MEASUREMENTS NOT WITHIN THE LIMITS OUTLINED ABOVE ARE INDICATIVE OF A POTENTIAL SHOCK HAZARD AND MUST BE CORRECTED BEFORE RETURNING THE APPLIANCE TO THE CUSTOMER.

2. PRODUCT SAFETY NOTICE

Many electrical and mechanical parts in the appliance have special safety related characteristics. These are often not evident from visual inspection nor the protection afforded by them necessarily can be obtained by using replacement components rated for voltage, wattage, etc. Replacement parts which have these special safety characteristics are identified in this Service Manual.

Electrical components having such features are identified by marking with a Δ on the schematics and on the parts list in this Service Manual.

The use of a substitute replacement component which does not have the same safety characteristics as the PIONEER recommended replacement one, shown in the parts list in this Service Manual, may create shock, fire, or other hazards.

Product Safety is continuously under review and new instructions are issued from time to time. For the latest information, always consult the current PIONEER Service Manual. A subscription to, or additional copies of, PIONEER Service Manual may be obtained at a nominal charge from PIONEER.

(FOR EUROPEAN MODEL ONLY)

VARO!
AVATTAESSA JA SUOJALUKITUS OHITETTAESSA OLET ALTTIINA NÄKYMÄTTÖMÄLLE LASERSATEILYLLE. ÄLÄ KATSO SÄTEESEEN.



LASER
Kuva 1
Lasersateilyn varoitusmerkki

WARNING!
DEVICE INCLUDES LASER DIODE WHICH EMITS INVISIBLE INFRARED RADIATION WHICH IS DANGEROUS TO EYES. THERE IS A WARNING SIGN ACCORDING TO PICTURE 1 INSIDE THE DEVICE CLOSE TO THE LASER DIODE.



LASER
Picture 1
Warning sign for laser radiation

ADVERSEL:
USYNLIG LASERSTRÅLING VED ÅBNING NÅR SIKKERHEDSAFBRYDERE ER UDE AF FUNKTION UNDGÅ UDSÆTTELSE FOR STRÅLING.

VARNING!
OSYNLIG LASERSTRÅLNING NÅR DENNA DEL ÄR ÖPPNAD OCH SPÄRREN ÄR URKOPPLAD. BETRAKTA EJ STRÅLEN.

IMPORTANT
THIS PIONEER APPARATUS CONTAINS LASER OF CLASS 1. SERVICING OPERATION OF THE APPARATUS SHOULD BE DONE BY A SPECIALLY INSTRUCTED PERSON.

LASER DIODE CHARACTERISTICS
MAXIMUM OUTPUT POWER: 5 mw
WAVELENGTH: 780-785 nm

LABEL CHECK

WB, WE and WEWM types



WE and WEWM types

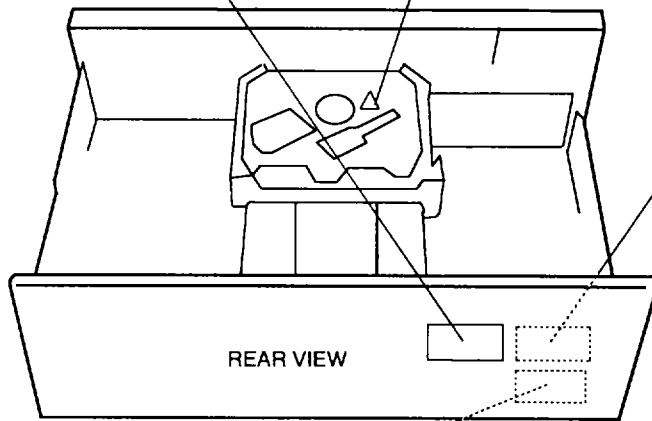
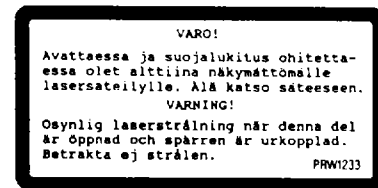

REAR VIEW

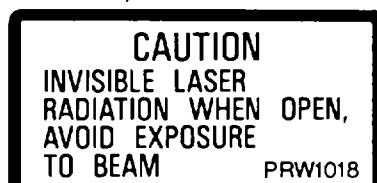
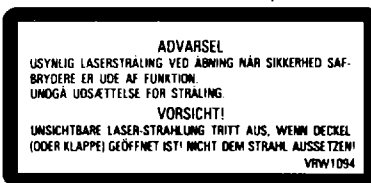

WE and WEWM types

WB type

Additional Laser Caution

- Laser Interlock Mechanism**
The position of the switch (S601) for detecting loading completion is detected by the system microprocessor, and the design prevents laser diode oscillation when the switch (S601) is not CLMP terminal side (when CLMP signal is OFF, that is, high level). Thus, the interlock will no longer function if the switch (S601) is deliberately set to CLMP terminal side (if CLMP signal is low level). In the test mode *, the interlock mechanism will not function. Laser diode oscillation will continue, if pin 1 of M51593FP (IC101) on the preamplifier board loaded on pickup assembly are connected to GND, or pin 19 is connected to low level (ON), or else the terminals of Q101 are shorted to each other (fault condition).
- When the cover is opened with the servo mechanism block removed to be turned over, close viewing of the objective lens with the naked eye will cause exposure to a Class 1 laser beam.

* : Refer to page 24.

2. EXPLODED VIEWS, PACKING AND PARTS LIST

NOTES:

- Parts marked by "NSP" are generally unavailable because they are not in our Master Spare Parts List.
- The \triangle mark found on some component parts indicates the importance of the safety factor of the part. Therefore, when replacing, be sure to use parts of identical designation.
- Parts marked by "⊙" are not always kept in stock. Their delivery time may be longer than usual or they may be unavailable.

1. EXTERIOR

Parts List

Mark	No.	Description	Part No.
\triangle	1	Strain relief	CM - 22C
	2	21P F.F.C./30V	PDD1154
\triangle	3	AC power cord	PDG1015
NSP	4	Under base	PNA2038
	5	Bonnet	PNA2039
	6	Insulator	PNW2363
	7	Display window	PAM1633
	8	LED lens	PNW2019
	9	Sub panel	PNW2361
	10	Holder	PNW2362
	11	Name plate	RAN1013
	12	Washer	RBF1017
	13	Screw	BPZ26P080FMC
	14	Screw	BBZ30P100FCC
	15	Screw	BBZ30P080FCC
	16	Screw	IBZ30P150FCC
	17	Screw	BSZ30P070FMC
NSP	18	Spacer	PNY - 404
\triangle	19	MOTHER BOARD ASSY	PWM1833
	20	OPERATION BOARD ASSY	PWZ2681
\triangle	21	SERVO TRANSFORMER BOARD ASSY	PWZ2686
NSP	22	Loading mechanism assy	PXA1521
\triangle	23	Power transformer	PTT1296
	24	Name plate	PAN1296
	25	Front panel	PNW2482
NSP	26	Cord clamper	DNF1128
NSP	27	Shield tube	PDM1018
NSP	28	Rear panel	PNA2055
NSP	29	Angle	PNB1467
NSP	30	Cushion	PNM1176
	31	Screw	PDZ30P050FMC
	32	Screw	BBT30P080FCC
	33	65 label	ORW1069
	34	Cushion label	PRW1244
	35	Binder	Z09 - 056

NOTE: Screws adjacent to ▼ mark on the product are used for disassembly.

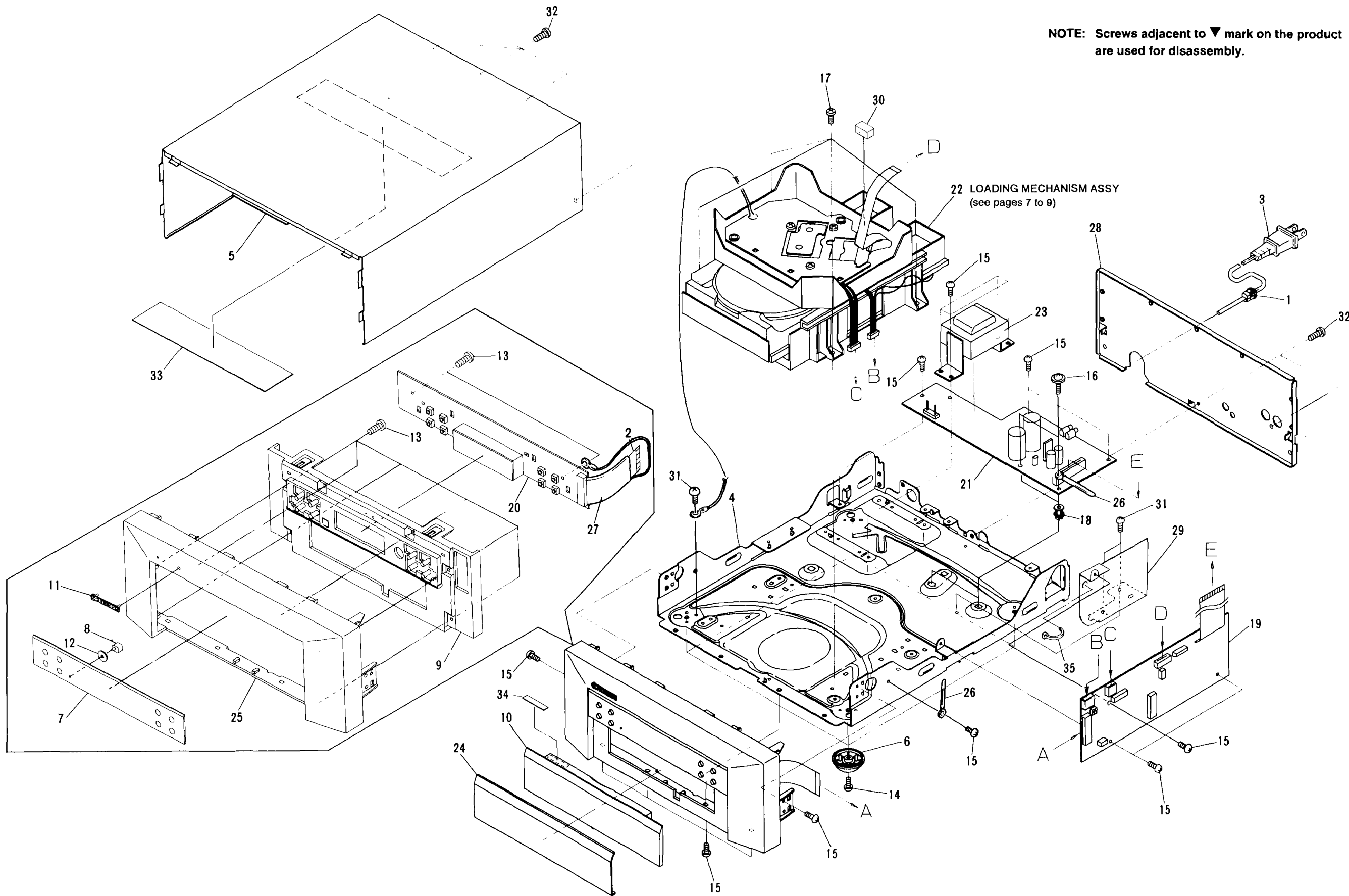

2. LOADING MECHANISM ASSY

A

B

C

D

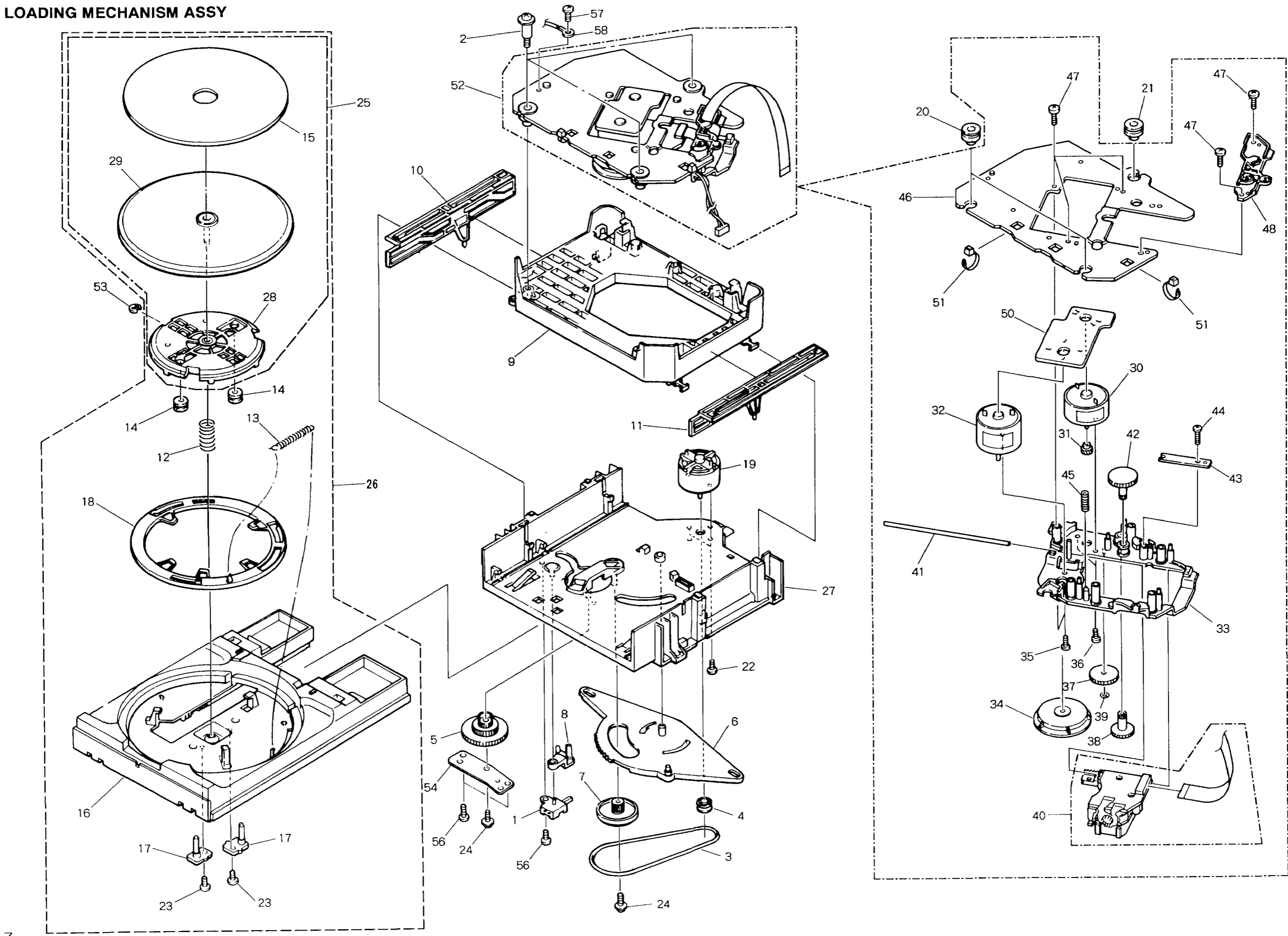

A

B

C

D

2. LOADING MECHANISM ASSY

Parts List

Mark	No.	Description	Part No.	Mark	No.	Description	Part No.
	1	Lever switch (S601)	DSK1003	NSP	46	Mechanism base TT	PNB1431
	2	Float screw	PBA1027		47	Screw	BPZ26P100FMC
	3	Rubber belt	PEB1186		48	PWB holder	PNW2057
	4	Motor pulley	PNW1634		49	
	5	Drive gear	PNW1996	NSP	50	MECHANISM BOARD ASSY	PWX1192
	6	Synchronized lever	PNW2168		51	Binder	PEC - 107
	7	Gear pulley	PNW1998	NSP	52	Servo mechanism assy TT92	PXA1479
	8	SW head	PNW1999		53	Stop ring	YE20S
	9	Float base	PNW2000		54	Shaft holder	PNB1382
	10	Left cam	PNW2001		55	
	11	Right cam	PNW2002		56	Screw	BPZ26P060FMC
	12	Float spring	PBH1120		57	Screw	BBZ26P060FMC
	13	Lock spring	PBH1121	NSP	58	Earth lead unit	PDF1148
	14	Float rubber	PEB1014				
	15	Table rubber sheet	PEB1181				
	16	Tray	PNW2003				
	17	Table guide	PNW2004				
	18	Lock plate	PNW2005				
	19	D.C. motor (0.75W, LOADING)	PXM1010				
	20	Float rubber	PEB1031				
	21	Float rubber	PEB1170				
	22	Screw	BMZ26P040FMC				
	23	Screw	IPZ26P060FCU				
	24	Screw	IPZ20P080FMC				
	25	Turn table assy	PEA1165				
NSP	26	Tray assy	PXA1397				
NSP	27	Loading base	PNW1995				
NSP	28	Table shaft holder	PXA1383				
NSP	29	Turn table (AL)	PNR1035				
NSP	30	Carriage D.C. motor (0.3W)	PXM1027				
	31	Pinion gear	PNW2055				
	32	D.C. motor assy (SPINDLE, with oil)	PEA1156				
	33	Carriage base	PNW2445				
	34	Disc table	PNW1067				
	35	Screw	JFZ20P030FNI				
	36	Screw	JFZ17P025FZK				
	37	Gear 3	PNW2054				
	38	Gear 2	PNW2053				
	39	Washer	WT12D032D025				
	40	Pickup assy	PEA1179				
	41	Guide bar	PLA1094				
	42	Gear 1	PNW2052				
NSP	43	Gear stopper	PNB1303				
	44	Screw	BPZ20P060FMC				
	45	Earth spring	PBH1132				

• How to install the disc table

1 Use nipper or other tool to cut the three sections marked (A) figure 1. Then remove the spacer.

2 While supporting the spindle motor shaft with the stopper, put spacer on top of the motor base (angled so it doesn't touch section (B)), and stick the disc table on top (takes about 9Kg pressure). Take off the spacer.

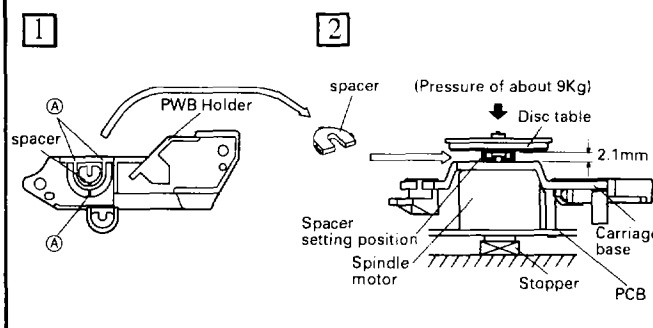

3. PACKING

Parts List

Mark	No.	Description	Part No.
	1	Styrol protector F	PHA1270
	2	Styrol protector R	PHA1271
	3	Operating instructions (English)	PRB1204
	4	Sheet	Z23 - 007
	5	Cord with mini plug	PDE1247
	6	Cord with plug	PDE1065
	7	Packing case	PHG2063

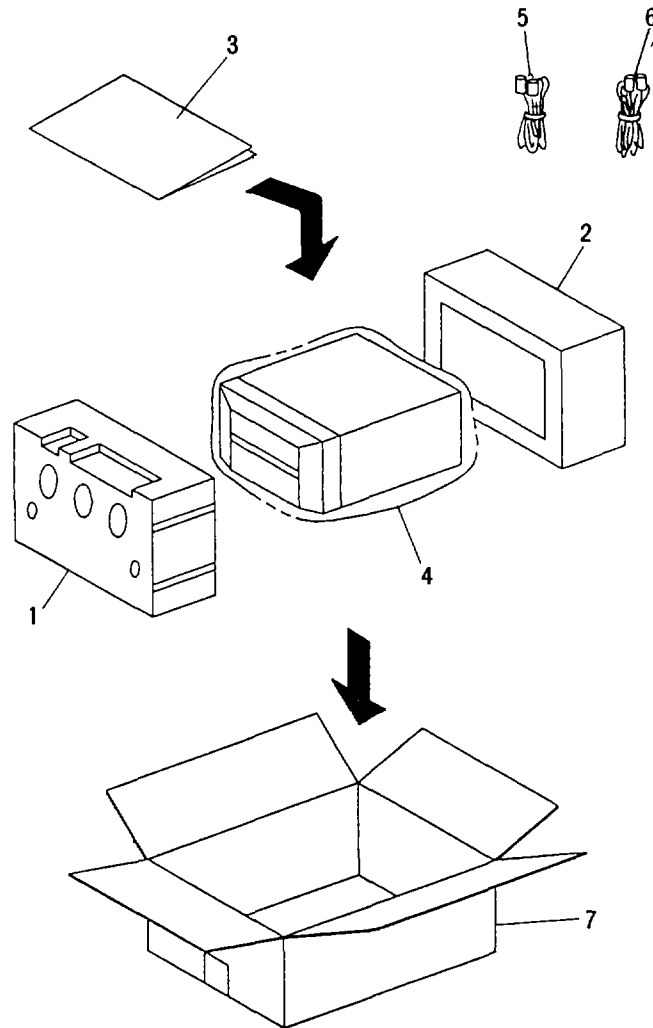

3. BLOCK DIAGRAM

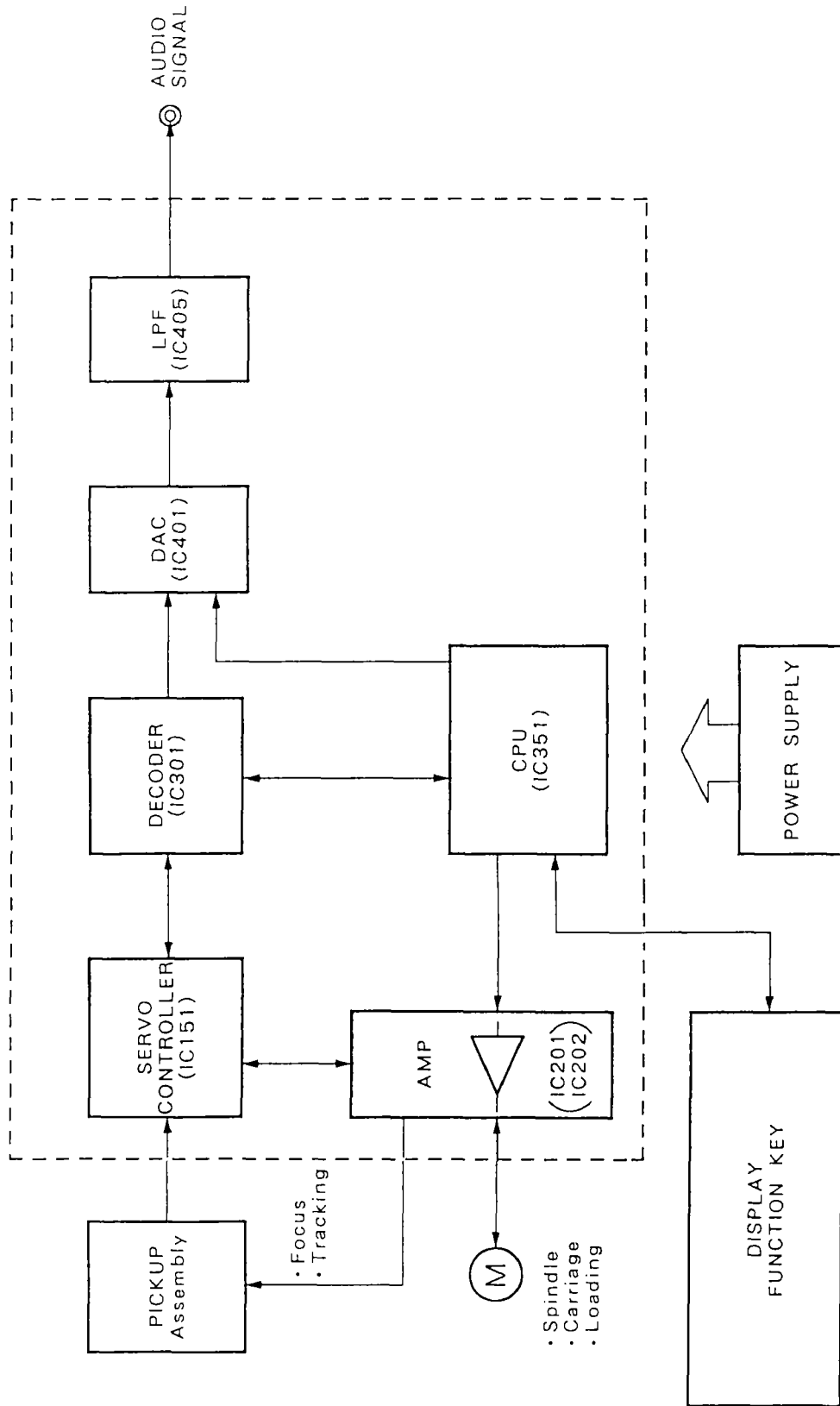

4. SCHEMATIC DIAGRAM

Waveforms

Note: The encircled numbers denote measuring points in the schematic diagram.

*1 50T-JUMP: After switching to the pause mode, press the manual search key.

*2 FOCUS-IN: Press the key without loading a disc.

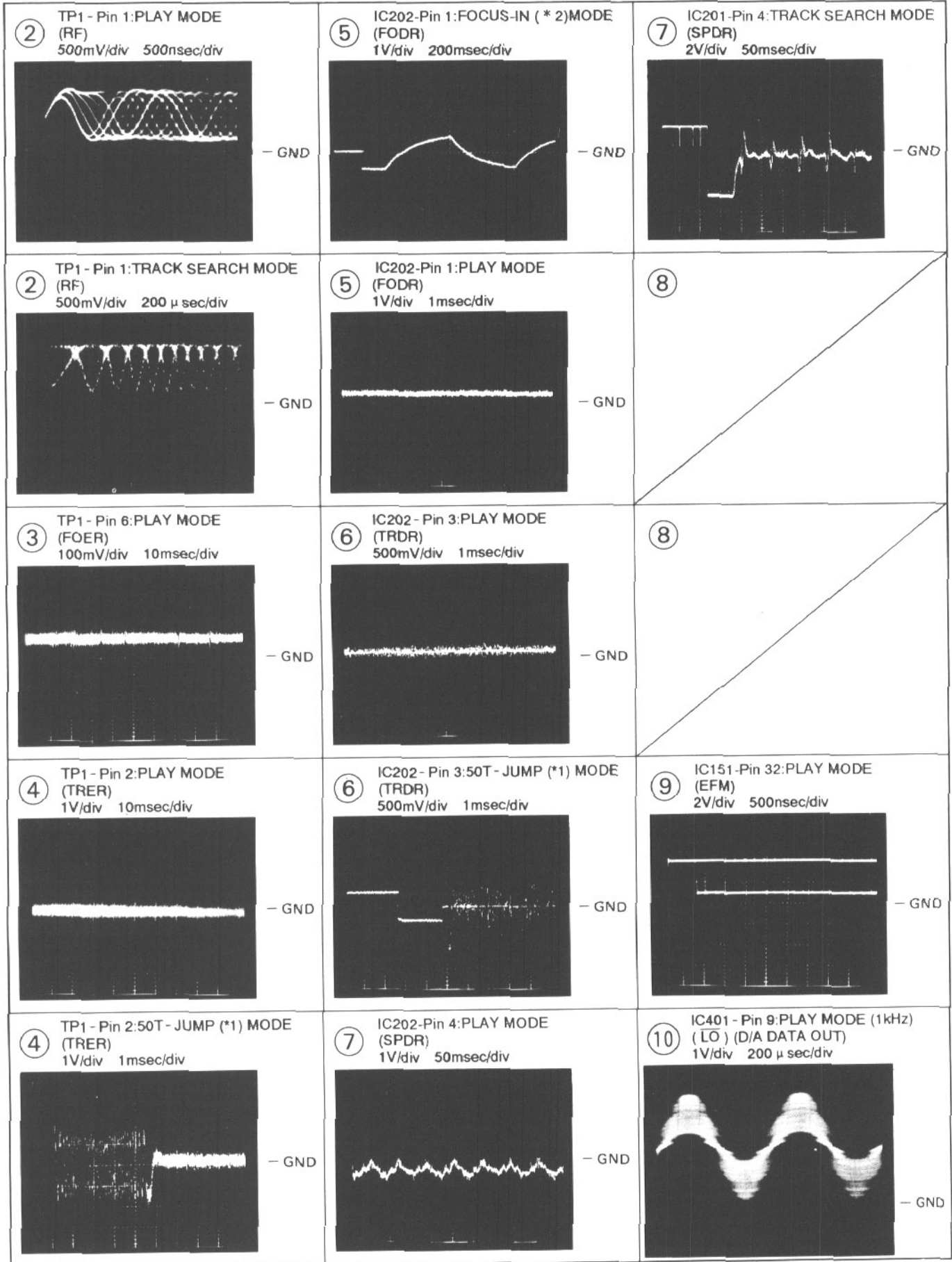

11 IC401 - Pin 10:PLAY MODE (1kHz)
(LO) (D/A DATA OUT)
1V/div 200 μ sec/div

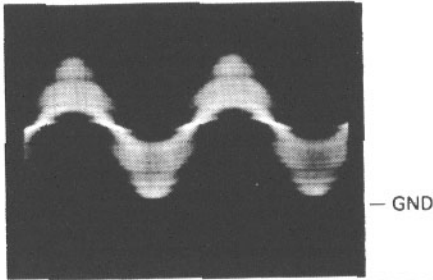

22 IC20-Pin 4:POWER SWITCH- ON
(RST)
2V/div 100msec/div

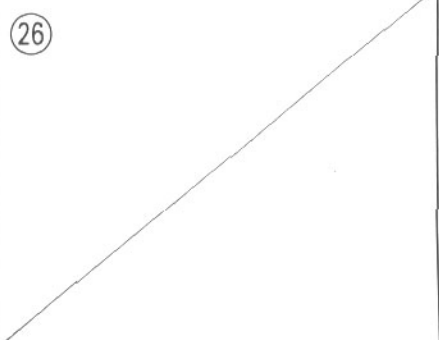
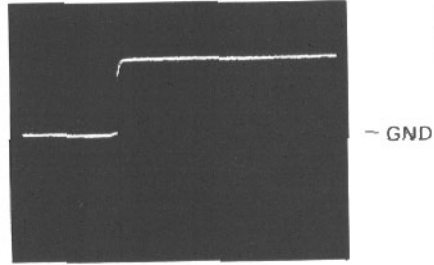

16 IC301 - Pin 35:PLAY MODE (1kHz)
(BCLK)
2V/div 500nsec/div

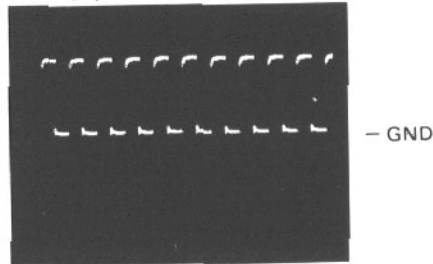

22 IC20-Pin 4:POWER SWITCH-OFF
(RST)
2V/div 100msec/div

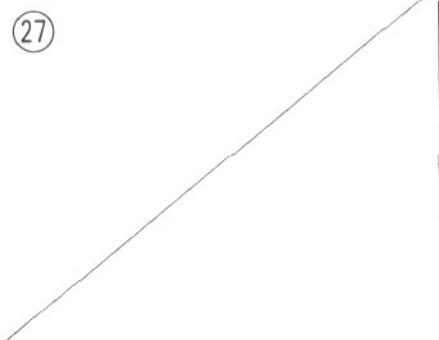
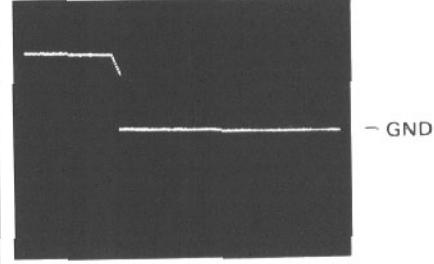

18 IC301 - Pin 32:PLAY MODE (1kHz)
(LRCK)
2V/div 10 μ sec/div

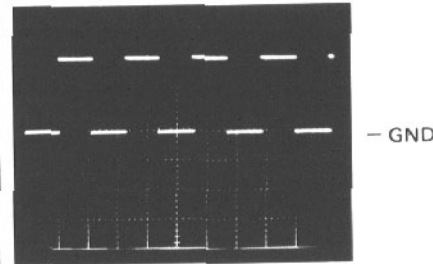

23 TRACK SEARCH MODE
Upper:TP1 - Pin 1 (RF) 1V/div
Lower:IC151-Pin 29(MIRR)
2V/div 200 μ sec/div

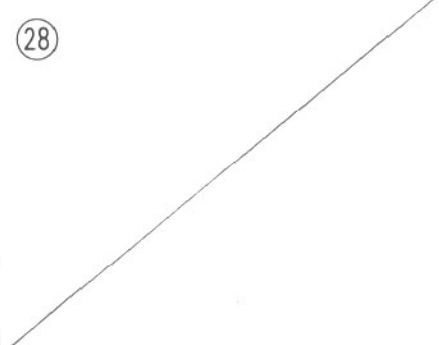
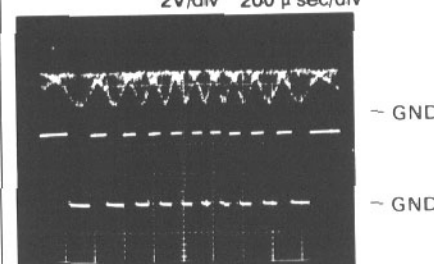

19 IC301 - Pin 34:PLAY MODE (1kHz)
(DATA)
2V/div 500nsec/div

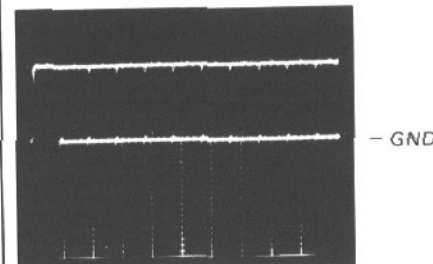

24 PLAY MODE
Upper:TP1-Pin 1(RF)1V/div
Lower:IC151-Pin 30(DFCT)
5V/div 200 μ sec/div

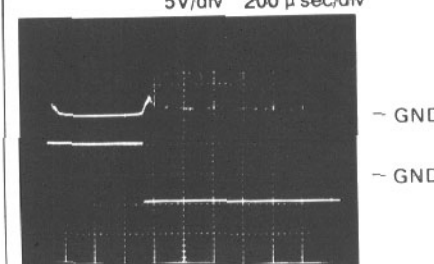

33 IC301 - Pin 4:PLAY MODE
(MDP)
2V/div 2 μ sec/div

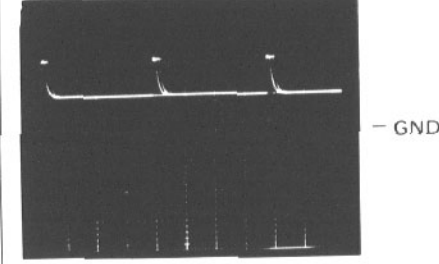

21 Pin - OUTPUT:PLAY MODE(1kHz)
1V/div 200 μ sec/div

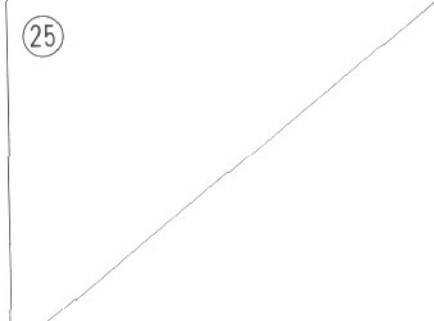
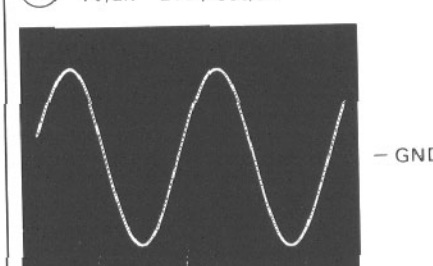

53 IC301 - Pin 20:PLAY MODE
(PCO)
2V/div 10 μ sec/div

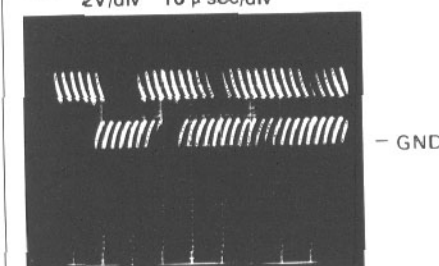

IC151 : CXA1372Q

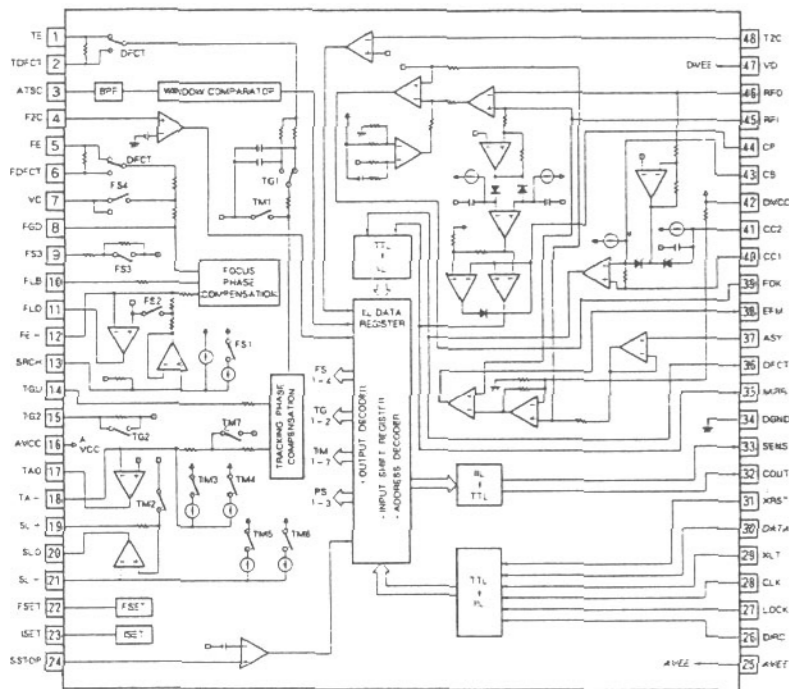

IC301 : CXD2500BQ

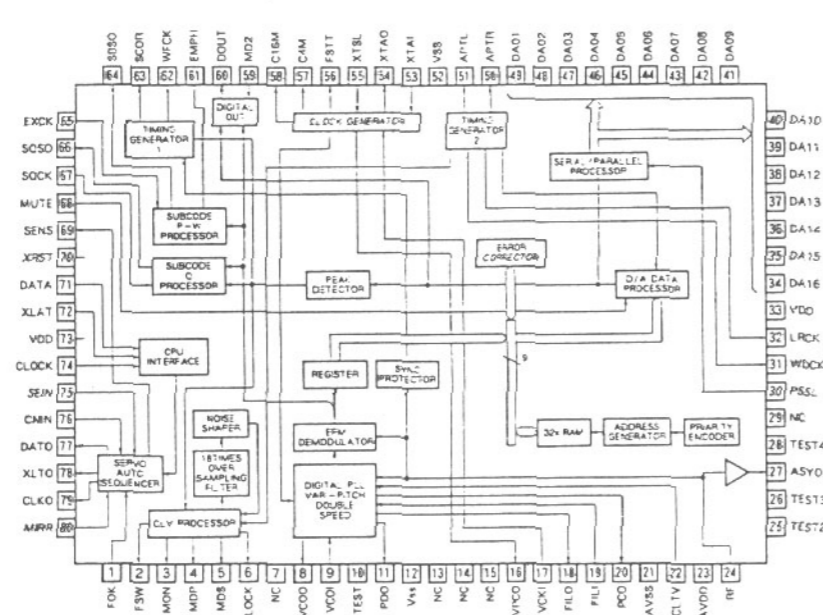

IC401 : PD2029A

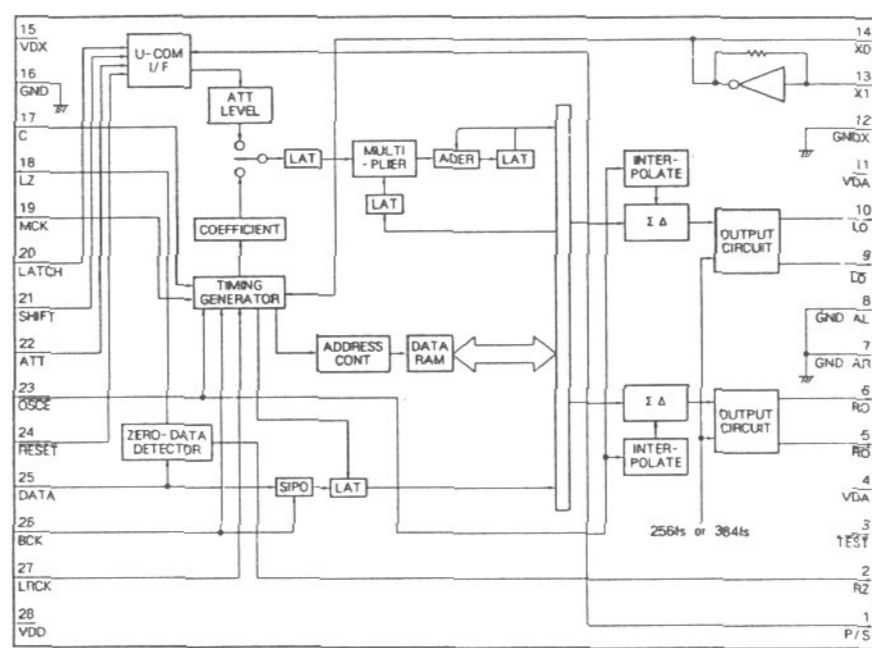

NOTE FOR SCHEMATIC DIAGRAMS

(Type 4A)

1. When ordering service parts, be sure to refer to "PARTS LIST of EXPLODED VIEWS" or "PCB PARTS LIST".

2. Since these are basic circuits, some parts of them or the values of some components may be changed for improvement.

3. RESISTORS:

Unit: k: k Ω , M: M Ω , or Ω unless otherwise noted.

Rated power: 1/4W, 1/6W, 1/8W, 1/10W unless otherwise noted.

Tolerance: (F): $\pm 1\%$, (G): $\pm 2\%$, (K): $\pm 10\%$, (M): $\pm 20\%$ or $\pm 5\%$ unless otherwise noted.

4. CAPACITORS:

Unit: p: pF or μ F unless otherwise noted.Ratings: capacitor (μ F)/ voltage (V) unless otherwise noted. Rated voltage: 50V except for electrolytic capacitors.

5. COILS:

Unit: m: mH or μ H unless otherwise noted.

6. VOLTAGE AND CURRENT:

□ or - V :

DC voltage (V) in PLAY mode unless otherwise noted.

⊕ mA or - mA :

DC current in PLAY mode unless otherwise noted.

Value in () is DC current in STOP mode.

7. OTHERS:

• ⊕ or ⊖ : Adjusting point.

• ⊕ : Measurement point.

• The Δ mark found on some component parts indicates the importance of the safety factor of the parts. Therefore, when replacing, be sure to use parts of identical designation.

8. SCH-□ ON THE SCHEMATIC DIAGRAM:

• SCH-□ indicates the drawing number of the schematic diagram. (SCH stands for schematic diagram.)

9. SWITCHES (Underline indicates switch position):

OPERATION BOARD ASSY

S701 :

S702 :

S703 : Power standby/on

S704 : PGM

S705 : (STOP)

S706 : (Open/Close)

S707 : Repeat

S708 : (Play, Pause)

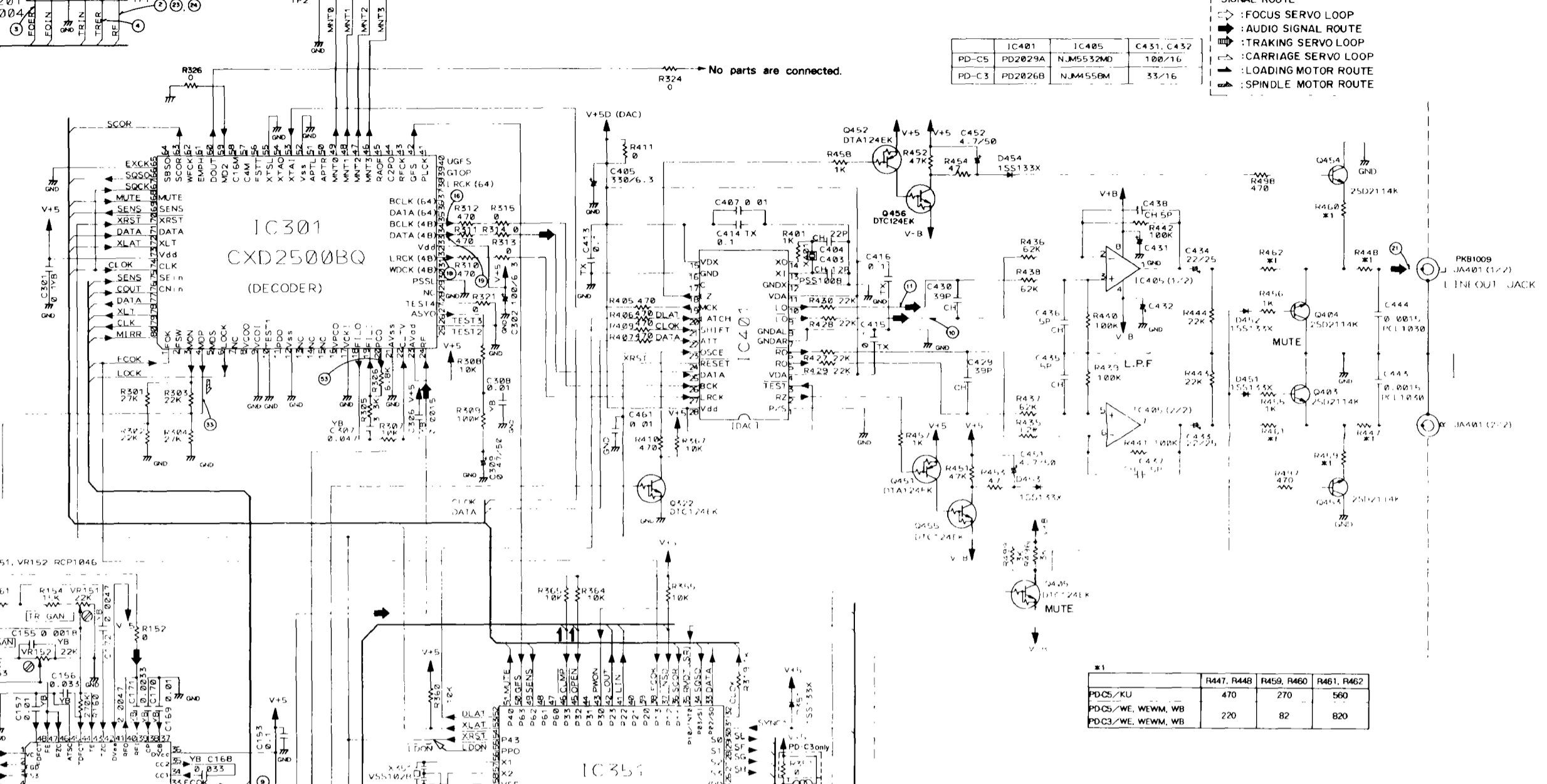
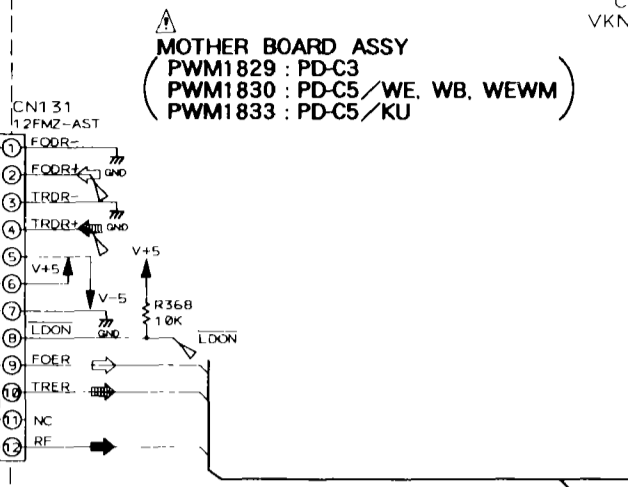
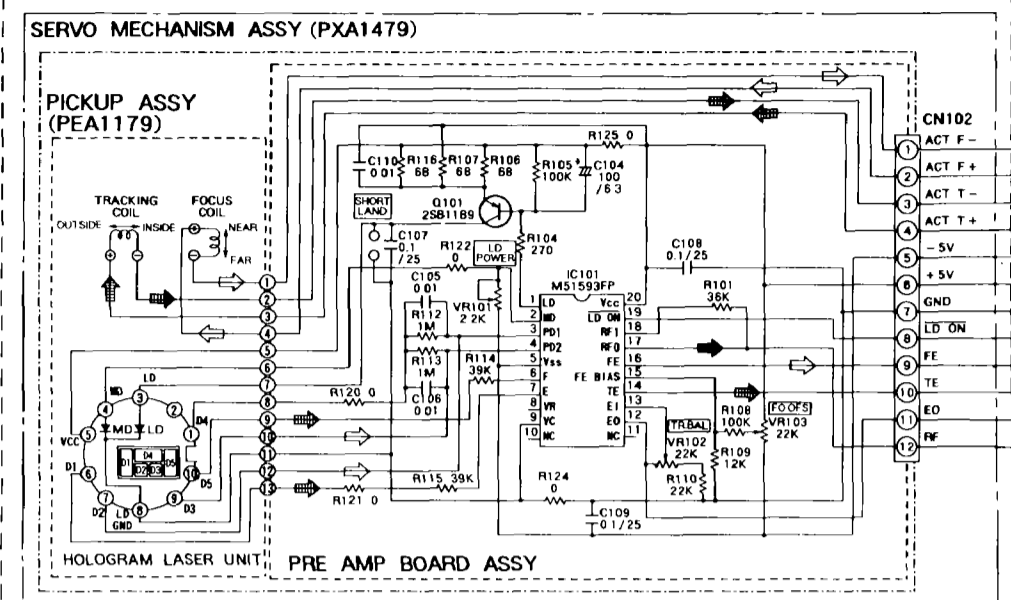

IC401	IC405	C451, C452
PD-C5 PD2829A	NJM5552M	100/16
PD-C3 PD2826B	NJM5556M	53/16

SIGNAL ROUTE
 ○: FOCUS SERVO LOOP
 □: AUDIO SIGNAL ROUTE
 △: TRACKING SIGNAL ROUTE
 ◇: CARRIAGE SERVO LOOP
 ☆: LOADING MOTOR ROUTE
 ○: SPINDLE MOTOR ROUTE

IC301 (CXD2500BQ)

No.	Pin	Voltage [V]	Pin	Voltage [V]	Pin	Voltage [V]
1	5	0	71	0	41	NC
2	0	72	75	0	47	5
3	0	73	5	0	43	NC
4	2	74	75	0	44	NC
5	0	75	NC	45	NC	
6	5	76	0	46	4	
7	0	77	2	5	47	0
8	NC	78	NC	48	0	
9	0	79	0	49	11	
10	0	30	NC	50	NC	
11	NC	31	13	77	51	
12	0	32	2	52	0	
13	NC	33	5	0	53	
14	NC	34	2	5	0	
15	NC	35	NC	54	5	
16	NC	36	NC	55	0	
17	0	37	NC	56	7	
18	2	38	NC	57	2	
19	2	39	NC	58	0	
20	2	40	NC	59	0	
21	2	41	NC	60	0	

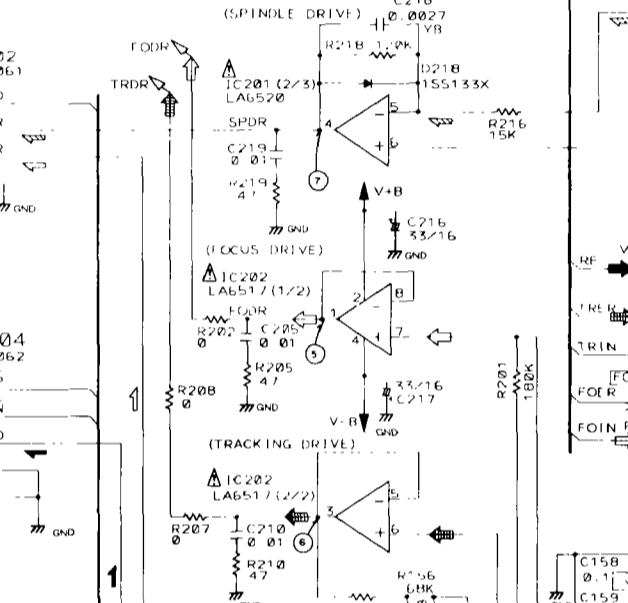

IC151 (CX13770)

No.	Pin	Voltage [V]	Pin	Voltage [V]	Pin	Voltage [V]
1	0	25	5	0	3	5
2	0	26	0	3	0	0
3	0	27	5	0	4	0
4	0	28	0	4	5	0
5	0	29	0	5	0	0
6	0	30	5	0	6	0
7	0	31	2	5	7	0
8	0	32	2	5	8	0
9	0	33	5	0	9	0
10	5	34	1	5	10	0
11	0	35	1	7	11	0
12	0	36	5	0	12	0
13	0	37	0	7	13	0
14	1	38	1	0	14	0
15	0	39	0	0	15	0
16	4	40	0	8	16	0
17	1	41	5	0	17	0
18	0	42	0	0	18	0
19	5	43	0	0	19	0
20	5	44	0	0	20	0
21	5	45	0	0	21	0
22	5	46	0	0	22	0
23	5	47	0	0	23	0
24	5	48	0	0	24	0

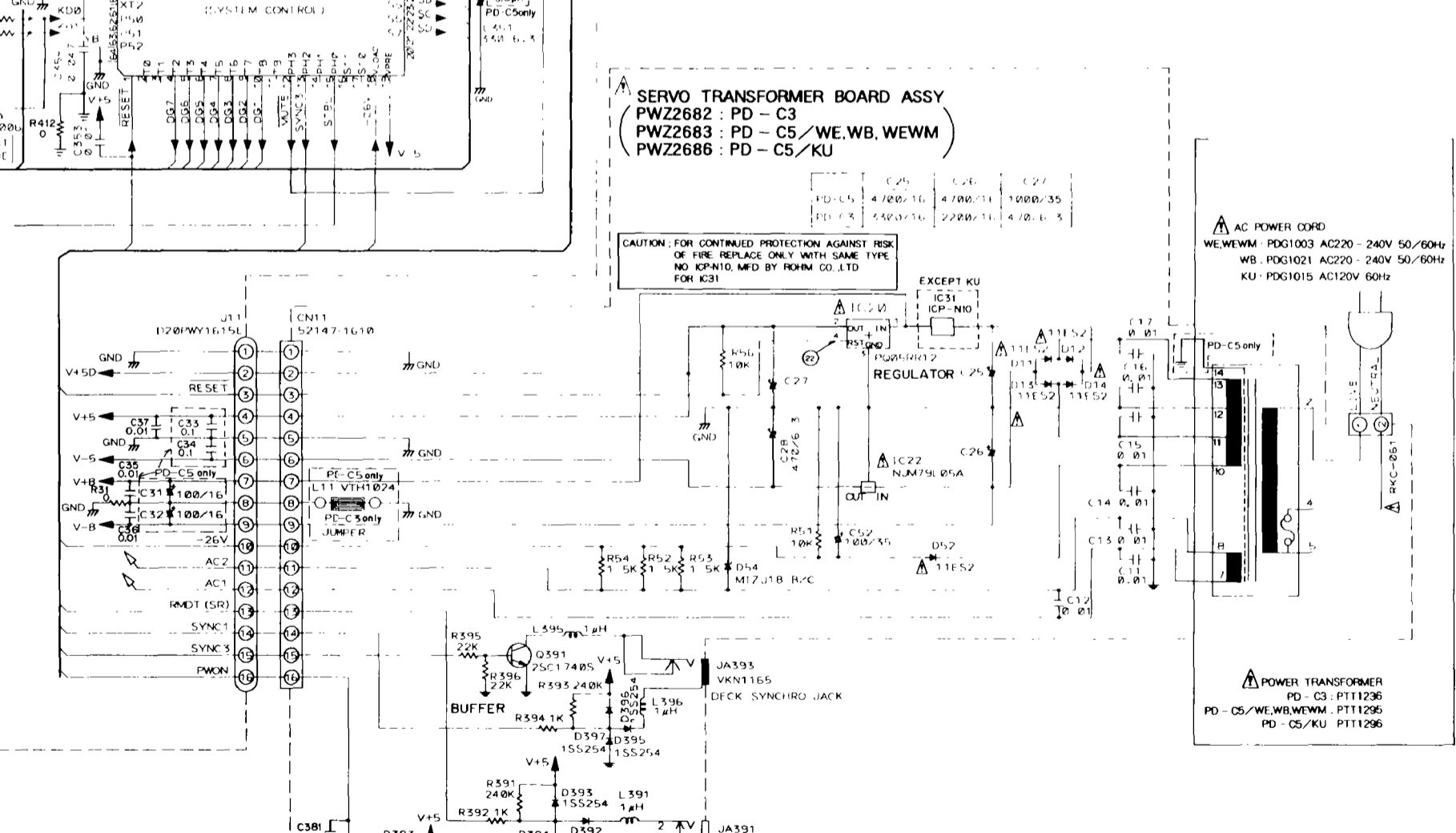
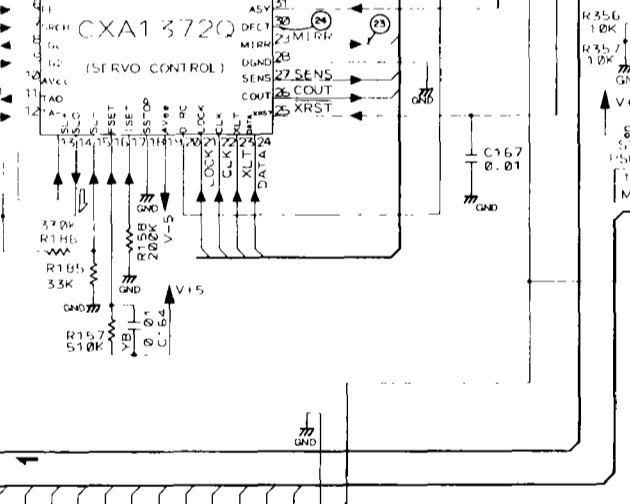
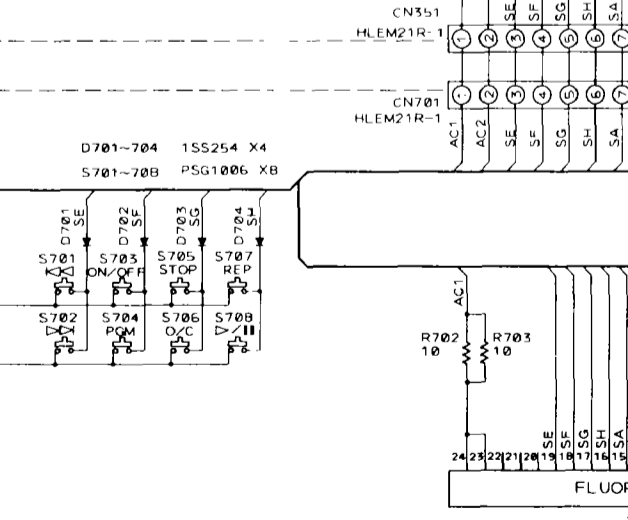
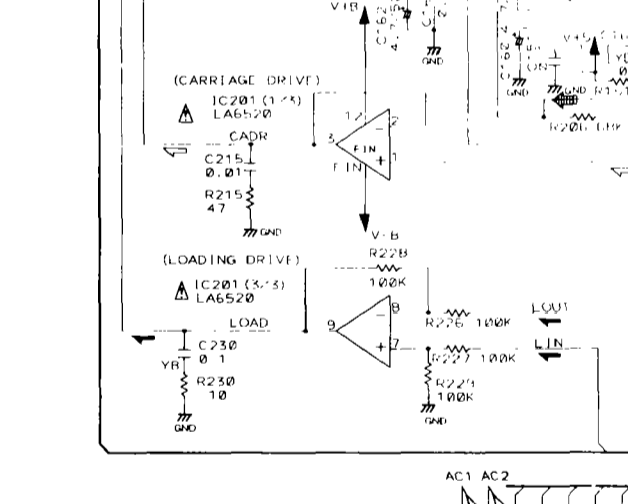

- [NOTES]**
- RESISTORS**
 (1) MOTHER PCB ASS'Y (except for VR) 1/10W Type
 (2) SUB PCB ASS'Y 1/6W Type
- CAPACITORS**
 (1) CH Ceramic CCKSQCH
 (2) YB Ceramic CKSQYB
 (3) TX Film CFTXA
 (4) Unmarked type
 MOTHER PCB ASS'Y CCKSQYF
 (5) Unmarked type
 SUB PCB ASS'Y CKCYF
 (6) Unmarked Electrolysis
 MOTHER PCB ASS'Y CEJA
 (7) Unmarked Electrolysis
 SUB PCB ASS'Y CEAS
- INDUCTORS**
 (1) Unmarked type LAU
- OTHERS**
 ↓ CHASSIS GROUND
 ABC LOW ACTIVE SIGNAL
- SUB BOARD ASSY**
 PWX1310 : PD-C3
 PWX1311 : PD-C5 / WE, WB, WEWM
 PWX1314 : PD-C5 / KU

A

B

C

D

E

F

A

B

C

D

E

F

5. PCB CONNECTION DIAGRAM

- This diagram is viewed from the pink colored foil side.
- This PCB is double sided.

NOTE FOR PCB DIAGRAMS:

1. Part numbers in PCB diagrams match those in the schematic diagrams.
2. A comparison between the main parts of PCB and schematic diagrams is shown below.

Symbol in PCB Diagrams	Symbol in Schematic Diagrams	Part Name
		Transistor
		Transistor with resistor
		Field effect transistor
		Resistor array
		3-terminal regulator

MOTHER BOARD ASSY

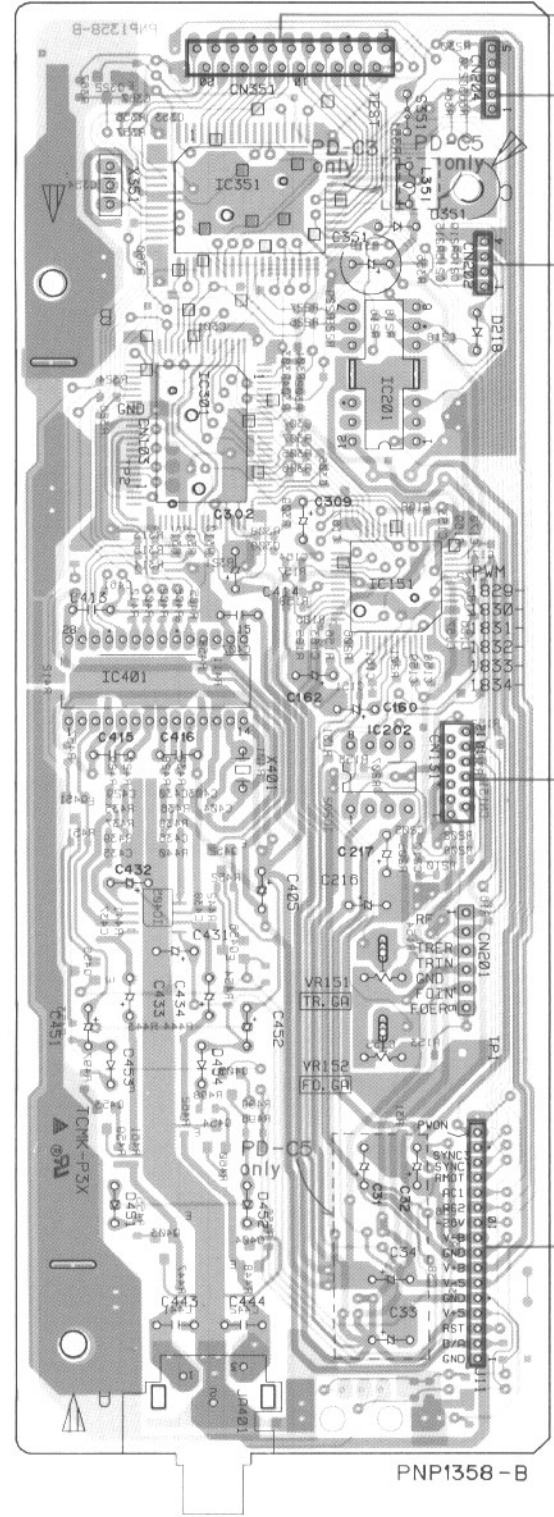

OPERATION BOARD ASSY
CN701

CLAMP SWITCH (S601)
LOADING MOTOR

MECHANISM BOARD ASSY

OPERATION BOARD ASSY

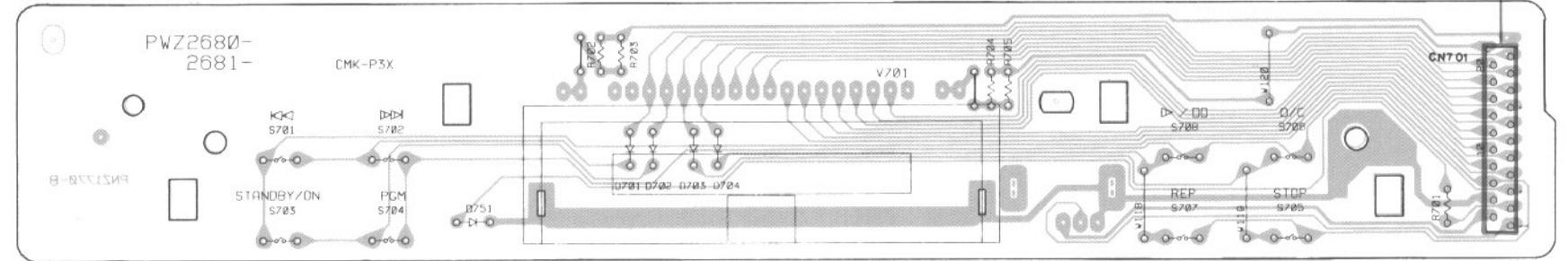

- This diagram is viewed from the mounted parts side.

PICKUP ASSY
Q391

IC22
IC20
IC30

SERVO TRANSFORMER BOARD ASSY

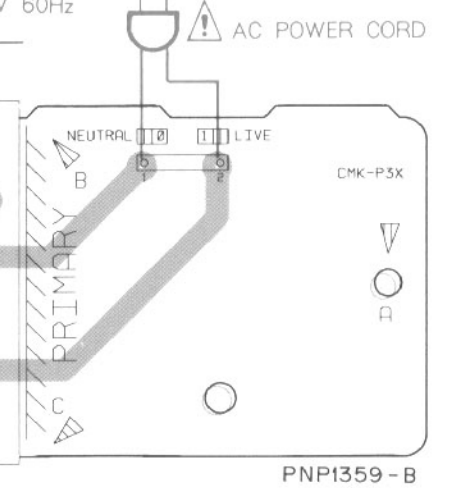
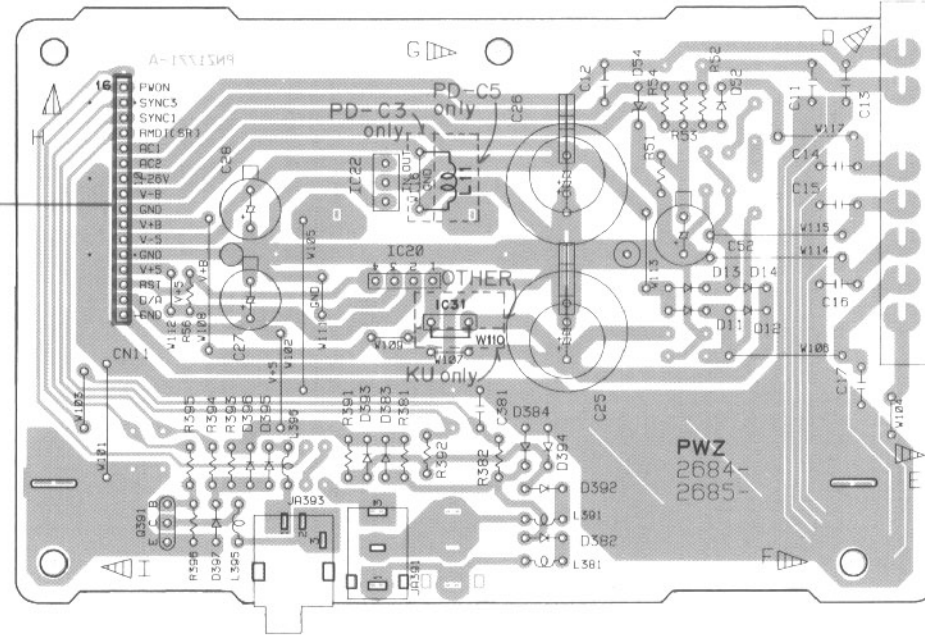

- This diagram is viewed from the mounted parts side.

A

B

C

D

- This diagram is viewed from the gray colored foil side.
- This PCB is double sided.

A

A

MOTHER BOARD ASSY

OPERATION BOARD ASSY
 CLAMP SWITCH (2601)
 LOADING MOTOR
 OPERATION BOARD ASSY
 CNT01

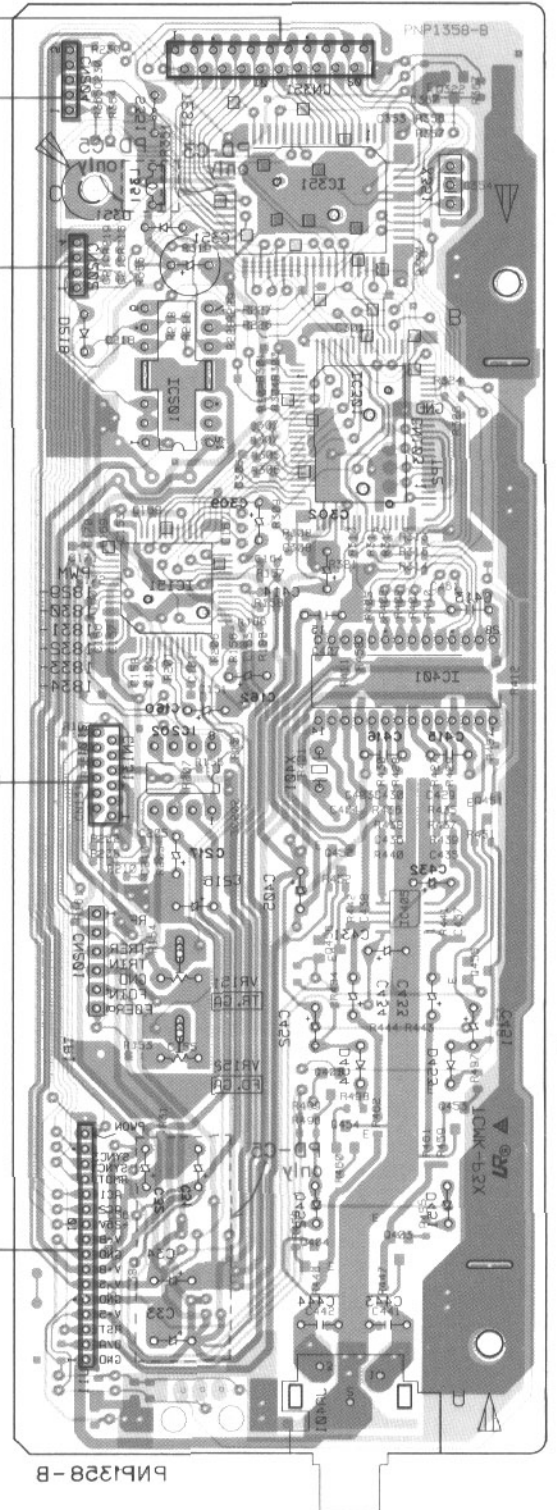

- Q322
- IC321
- IC304
- IC301
- IC121
- IC401
- IC501
- IC502
- Q451
- Q452
- IC405
- Q455
- VR121
- VR122
- VR123
- VR124
- VR125
- VR126
- VR127
- VR128
- VR129
- VR130
- VR131
- VR132
- VR133
- VR134
- VR135
- VR136
- VR137
- VR138
- VR139
- VR140
- VR141
- VR142
- VR143
- VR144
- VR145
- VR146
- VR147
- VR148
- VR149
- VR150
- VR151
- VR152
- VR153
- VR154
- VR155
- VR156
- VR157
- VR158
- VR159
- VR160
- VR161
- VR162
- VR163
- VR164
- VR165
- VR166
- VR167
- VR168
- VR169
- VR170
- VR171
- VR172
- VR173
- VR174
- VR175
- VR176
- VR177
- VR178
- VR179
- VR180
- VR181
- VR182
- VR183
- VR184
- VR185
- VR186
- VR187
- VR188
- VR189
- VR190
- VR191
- VR192
- VR193
- VR194
- VR195
- VR196
- VR197
- VR198
- VR199
- VR200

B

B

• This diagram is viewed from the foil side.

OPERATION BOARD ASSY

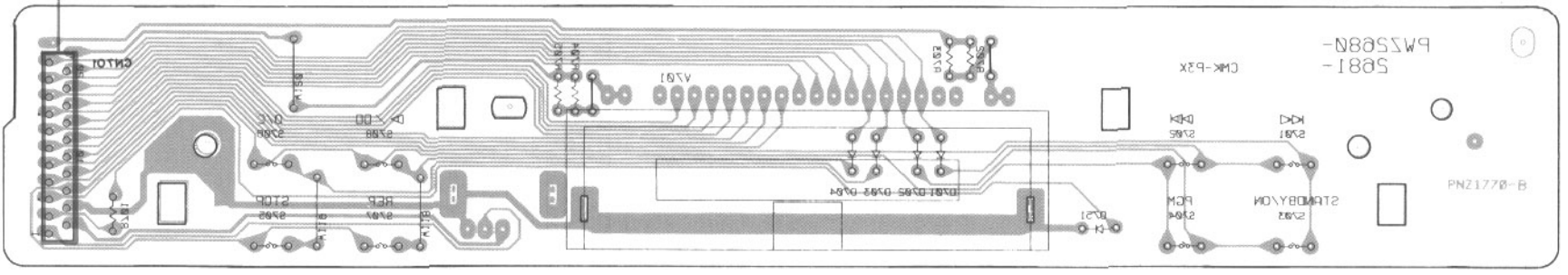

C

C

SERVO TRANSFORMER BOARD ASSY

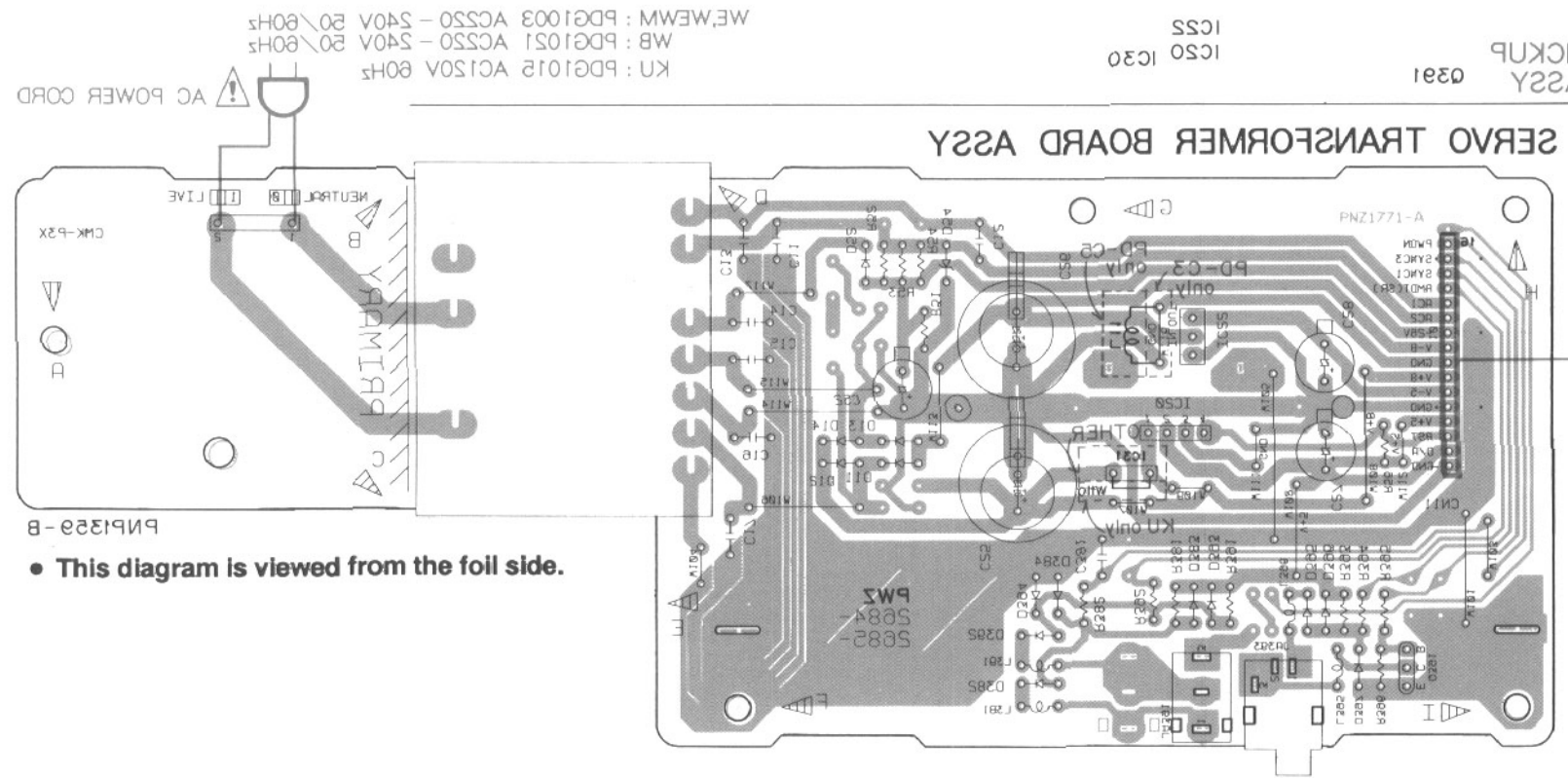

• This diagram is viewed from the foil side.

D

D

6. PCB PARTS LIST

NOTES:

- Parts marked by "NSP" are generally unavailable because they are not in our Master Spare Parts List.
- The Δ mark found on some component parts indicates the importance of the safety factor of the part. Therefore, when replacing, be sure to use parts of identical designation.
- Parts marked by "⊕" are not always kept in stock. Their delivery time may be longer than usual or they may be unavailable.
- When ordering resistors, first convert resistance values into code form as shown in the following examples.

Ex.1 When there are 2 effective digits (any digit apart from 0), such as 560 ohm and 47k ohm (tolerance is shown by J=5%, and K=10%).

560 Ω \rightarrow $56 \times 10^1 \rightarrow$ 561 RD1/8PM $\begin{matrix} 5 & 6 & 1 \\ \hline \end{matrix}$ J
 47k Ω \rightarrow $47 \times 10^3 \rightarrow$ 473 RD1/4PS $\begin{matrix} 4 & 7 & 3 \\ \hline \end{matrix}$ J
 0.5 Ω \rightarrow 0R5 RN2H $\begin{matrix} 0 & R & 5 \\ \hline \end{matrix}$ K
 1 Ω \rightarrow 010 RS1P $\begin{matrix} 0 & 1 & 0 \\ \hline \end{matrix}$ K

Ex.2 When there are 3 effective digits (such as in high precision metal film resistors).

5.62k Ω \rightarrow $562 \times 10^1 \rightarrow$ 5621 RN1/4PC $\begin{matrix} 5 & 6 & 2 & 1 \\ \hline \end{matrix}$ F

Mark	No.	Description	Part No.	Mark	No.	Description	Part No.
------	-----	-------------	----------	------	-----	-------------	----------

LIST OF ASSEMBLIES

Δ		MOTHER BOARD ASSY	PWM1833
NSP		MECHANISM BOARD ASSY	PWX1192
Δ NSP		SUB BOARD ASSY	PWX1314
		└ OPERATION BOARD ASSY	PWZ2681
Δ		└ SERVO TRANSFORMER BOARD ASSY	PWZ2686

MOTHER BOARD ASSY

SEMICONDUCTORS

	IC151	CXA1372Q
	IC301	CXD2500BQ
Δ	IC202	LA6517
Δ	IC201	LA6520
	IC405	NJM5532MD
	IC401	PD2029A
	IC351	PD4505A
	Q403, Q404, Q453, Q454	2SD2114K
	Q451, Q452	DTA124EK
	Q322, Q405, Q455, Q456	DTC124EK
	D218, D351, D451-D454	1SS133X

SWITCHES AND RELAYS

S351	PSG1006
------	---------

COILS AND FILTERS

L351	LFA3R3J
------	---------

CAPACITORS

C435-C438	CCSQCH050C50
C403	CCSQCH120J50
C404	CCSQCH220J50
C429, C430	CCSQCH390J50
C31, C32, C431, C432	CEJA101M16
C302	CEJA101M6R3
C433, C434	CEJA220M25
C216, C217	CEJA330M16
C351, C405	CEJA331M6R3
C160, C162, C451, C452	CEJA4R7M50

C309	CEJAR47M50
C33, C34, C413-C416	CPTXA104J50
C157, C164, C169, C308	CKSQYB103K50
C158, C159, C161, C163, C230	CKSQYB104K25
C301	CKSQYB104K25

C306	CKSQYB152K50
C155	CKSQYB182K50
C218	CKSQYB272K50
C170	CKSQYB332K50
C156, C168	CKSQYB333K25

C171, C172	CKSQYB472K50
C307, C354	CKSQYB473K25
C167, C205, C210, C215, C219	CKSQYF103Z50
C35, C353, C36, C37, C407	CKSQYF103Z50
C461	CKSQYF103Z50

C151, C153	CKSQYF104Z25
C443, C444 (0.0015/50V)	PCL1030

RESISTORS

VR151, VR152 (22K)	RCP1046
Other Resistors	RS1/10S□□□J

OTHERS

CN131 FPC CONNECTOR (12P)	12FMZ-AST
CN351 FFC CONNECTOR (21P)	HLEM21R
JA401 PIN JACK (2P)	PKB1009
X401 CRYSTAL RESONATOR (16.9344MHZ)	PSS1008
CN202 AMP CONNECTOR (4P)	VKN1061
CN204 AMP CONNECTOR (5P)	VKN1062
X351 CERAMIC RESONATOR(4.19MHZ)	VSS1028
CN201 6P SIDE POST	VKN-004

MECHANISM BOARD ASSY

SWITCHES AND RELAYS

S610	DSG1016
------	---------

OTHERS

CN610 AMP CONNECTOR (4P)	VKN1061
--------------------------	---------

Mark	No.	Description	Part No.
------	-----	-------------	----------

OPERATION BOARD ASSY

SEMICONDUCTORS

D701-D704	1SS254
D751	PCX1019

SWITCHES AND RELAYS

S701-S708	PSG1006
-----------	---------

RESISTORS

All Resistors	RD1/6PM□□□J
---------------	-------------

OTHERS

CN701 FFC CONNECTOR (21P)	HLEM21R
V701 FL TUBE	PEL1078

SERVO TRANSFORMER BOARD ASSY

SEMICONDUCTORS

△ IC22	NJM79L05A
△ IC20	PQ05RR12
Q391	2SC1740S
△ D11-D14, D52	11ES2
D382-D384, D392-D397	1SS254
D54	MTZJ18B

COILS AND FILTERS

L381, L391, L395, L396	LAU010K
L11	VTH1024

CAPACITORS

C52	CEAS101M35
C27	CEAS102M35
C28	CEAS471M6R3
C25, C26	CEAS472M16
C15	CFTXA103J50
C11-C14, C16, C17, C381	CKCYF103Z50

RESISTORS

All Resistors	RD1/6PM□□□J
---------------	-------------

OTHERS

JA391 REMOTE CONTROL JACK (12V)	PKN1004
△ TERMINAL	RKC-061
JA393 MINI JACK	VKN1165

7. ADJUSTMENTS

● Adjustment Methods

If a disc player is adjusted incorrectly or inadequately, it may malfunction or not work at all even though there is nothing at all wrong with the pickup or the circuitry. Adjust correctly following the adjustment procedure.

● Adjustment Items/Verification Items and Order

If the specified values cannot be obtained or no adjustment is possible by performing the verifications or adjustments described in steps 1 – 4, the pickup block may be defective.

Step	Item	Test Point	Adjustment Location
1	Focus offset verification	TP1, Pin 6(FCS. ERR)	None
2	Tracking error balance verification	TP1, Pin 2(TRK. ERR)	None
3	Pickup radial/tangential direction tilt adjustment	TP1, Pin 1(RF)	Radial tilt adjustment screw, Tangential tilt adjustment screw
4	RF level verification	TP1, Pin 1(RF)	None
5	Focus servo loop gain adjustment	TP1, Pin 5(FCS. IN) TP1, Pin 6(FCS. ERR)	VR152(FCS. GAN)
6	Tracking servo loop gain adjustment	TP1, Pin 3(TRK. IN) TP1, Pin 2(TRK. ERR)	VR151 (TRK. GAN)

● Abbreviation table

FCS. ERR	:Focus Error
TRK. ERR	:Tracking Error
FCS GAN	:Focus Gain
TRK GAN	:Tracking Gain
FCS. IN	:Focus In
TRK. IN	:Tracking In

● Measuring Instruments and Tools

1. Dual trace oscilloscope (10:1 probe)
2. Low-frequency oscillator
3. Test disc (YEDS-7)
4. Low pass filter ($39k\Omega +0.001\mu F$)
5. Resistor ($100k\Omega$)
6. Standard tools

● Test Point and Adjustment Variable Resistor Positions

MOTHER BOARD ASSY

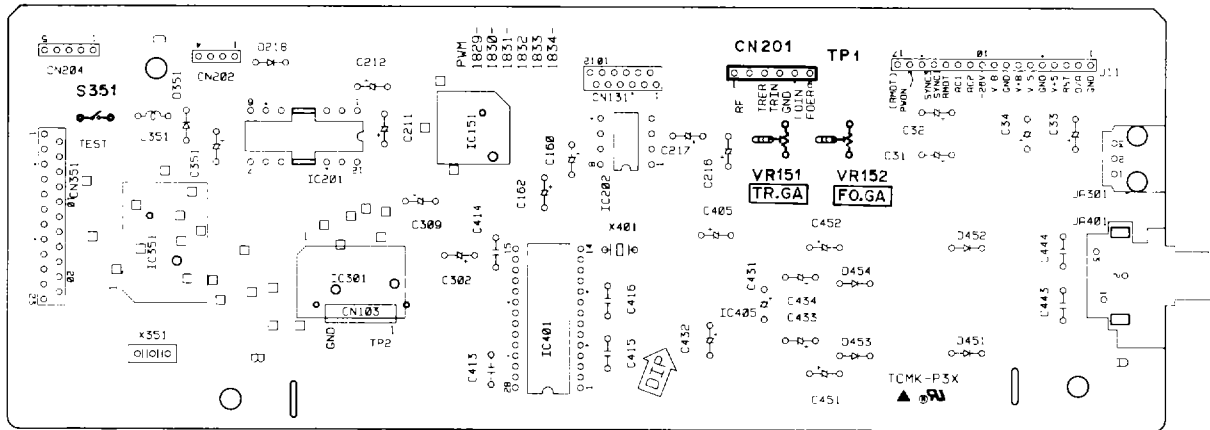

Figure 1. Adjustment Locations

● Notes

1. Use a 10:1 probe for the oscilloscope.
2. All the knob positions (settings) for the oscilloscope in the adjustment procedures are for when a 10:1 probe is used.

● Test Mode

These models have a test mode so that the adjustments and checks required for service can be carried out easily. When these models are in test mode, the keys on the front panel work differently from normal. Adjustments and checks can be carried out by operating these keys with the correct procedure. For these models, all adjustments are carried out in test mode.

[Setting these models to test mode]

How to set this model into test mode.

1. Unplug the AC power cord from the AC socket.
2. Push the test mode switch (S351). (See Figure 1.)
3. Plug the AC power cord back into the AC socket.

When the test mode is set correctly, the display is different from what it usually is when the power is turned on. If the display is still the same as usual, test mode has not been set correctly, so repeat Steps 1 – 3.





[Release from test mode]

Here is the procedure for releasing the test mode:

1. Press the STOP key and stop all operations.
2. Turn off the power switch on the front panel.

[Operations of the keys in test mode]

Code	Key Name	Function in Test Mode	Explanation
	PGM (PROGRAM)	Focus servo close	The laser diode is lit up and the focus actuator is lifted up, then lowered slowly and the focus servo is closed at the point where the objective lens is focused on the disc. With the player in this state, if you lightly rotate the stopped disc by hand, you can hear the sound the focus servo. If you can hear this sound, the focus servo is operating correctly. If you press this key with no disc mounted, the laser diode lights up, the focus actuator is pulled up, then the actuator is lowered and raised three times and returned to its original position.
▷/□□	PLAY/PAUSE	Spindle servo ON	Starts the spindle motor in the clockwise direction and when the disc rotation reaches the prescribed speed (about 500 rpm at the inner periphery), sets the spindle servo in a closed loop. Be careful. Pressing this key when there is no disc mounted makes the spindle motor run at the maximum speed. If the focus servo does not go correctly into a closed loop or the laser light shines on the mirror section at the outermost periphery of the disc, the same symptom is occurred.
▷/□□	PLAY/PAUSE	Tracking servo close/open	Pressing this key when the focus servo and spindle servo are operating correctly in closed loops puts the tracking servo into a closed loop, displays the track number being played back and the elapsed time on the front panel, and outputs the playback signal. If the elapsed time is not displayed or not counted correctly or the audio is not played back correctly, it may be that the laser is shining on the section with no sound recorded at the outer edge of the disc, that something is out of adjustment, or that there is some other problem. This key is a toggle key and open/close the tracking servo alternately. This key has no effect if no disc is mounted.

Code	Key Name	Function In Test Mode	Explanation
	TRACK / MANUAL SEARCH REV	Carriage reverse (inwards)	Moves the pickup position toward the inner diameter of the disc. When this key is pressed with the tracking servo in a closed loop, the tracking servo automatically goes into an open loop. Since the motor does not automatically stop at the mechanical end point in test mode, be careful with this operation.
	TRACK / MANUAL SEARCH FWD	Carriage forward (outwards)	Moves the pickup position toward the outer diameter of the disc. When this key is pressed with the tracking servo in a closed loop, the tracking servo automatically goes into an open loop. Since the motor does not automatically stop at the mechanical end point in test mode, be careful with this operation.
	STOP	Stop	Initializes and the disc rotation stops. The pickup and disc remain where they are when this key is pressed.
	OPEN/CLOSE	Disc tray open /close	Open/close the disc tray. This key is a toggle key and open/close tray alternately. Pressing this key when the disc is turning stops the disc, then opens the tray. This key operation does not affect the position of the pickup.

[How to play back a disc in test mode]

In test mode, since the servos operate independently, playing back a disc requires that you operate the keys in the correct order to close the servos.

Here is the key operation sequence for playing back a disc in test mode.

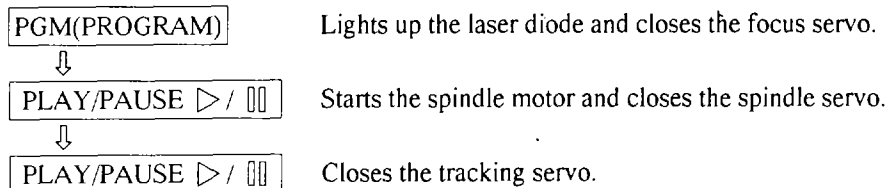

Wait at least 2-3 seconds between each of these operations.

1. Focus Offset Verification

● Objective	Verify the DC offset for the focus error amp.		
● Symptom when out of adjustment	The model does not focus in and the RF signal is dirty.		
● Measurement instrument connections	Connect the oscilloscope to TPI, Pin 6 (FCS. ERR) [Settings] 5 mV/division 10 ms/division DC mode	● Player state ● Adjustment location ● Disc	Test mode, stopped (just the Power switch on) None None needed
[Procedure] Verify the DC voltage at TPI, Pin 6 (FCS. ERR) is 0 ± 50 mV.			

Note : If the specified values cannot be obtained or no adjustment is possible by performing the verifications or adjustments described in adjustment items 1 – 4, the pickup block may be defective.

2. Tracking Error Balance Verification

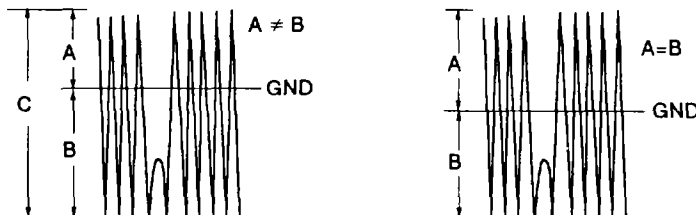
● Objective	To verify that there is no variation in the sensitivity of the tracking photo diode.		
● Symptom when out of adjustment	Play does not start or track search is impossible.		
● Measurement instrument connections	Connect the oscilloscope to TPI, Pin 2 (TRK. ERR). This connection may be via a low pass filter. [Settings] 50 mV/division 5 ms/division DC mode	● Player state ● Adjustment location ● Disc	Test mode, focus and spindle servos closed and tracking servo open None YEDS-7
[Procedure] 1. Move the pickup to midway across the disc (R=35 mm) with the TRACK/MANUAL SEARCH FWD $\triangleright\triangleright\triangleright$ or REV $\triangleleft\triangleleft\triangleleft$ key. 2. Press the PGM (PROGRAM) key, then the PLAY \triangleright key in that order to close the focus servo then the spindle servo. 3. Line up the bright line (ground) at the center of the oscilloscope screen and put the oscilloscope into DC mode. 4. Supposing that the positive amplitude of the tracking error signal at TPI, pin 2 (TRK ERR) is (A) and the negative amplitude is (B), the following expression is satisfied.			
When $A \geq B$, $\frac{A-B}{C} \times \frac{1}{2} \leq 0.1$ When $A < B$, $\frac{B-A}{C} \times \frac{1}{2} \leq 0.1$		 <p>When there is a DC component</p> <p>When there is no DC component</p>	

3. Pickup Radial/Tangential Direction Tilt Adjustment

<ul style="list-style-type: none"> ● Objective 	To adjust the angle of the pickup relative to the disc so that the laser beams are shone straight down into the disc for the best read out of the RF signals.		
<ul style="list-style-type: none"> ● Symptom when out of adjustment 	Sound broken; some discs can be played but not others.		
<ul style="list-style-type: none"> ● Measurement instrument connections 	Connect the oscilloscope to TPI, Pin 1 (RF). [Settings] 20 mV/division 200 ns/division AC mode	<ul style="list-style-type: none"> ● Player state 	Test mode, play
		<ul style="list-style-type: none"> ● Adjustment location 	Pickup radial tilt adjustment screw and tangential tilt adjustment screw
		<ul style="list-style-type: none"> ● Disc 	YEDS-7

[Procedure]

1. Press the TRACK/MANUAL SEARCH FWD $\gg \gg$ or REV $\ll \ll$ key to move the pickup to halfway across the disc (R=35mm).
Press the PGM (PROGRAM) key, the PLAY/PAUSE \triangleright / \square key two times in that order to close the respective servos and put the player into play mode.
2. First, adjust the radial tilt adjustment screw with a Phillips screwdriver so that the eye pattern (the diamond shape at the center of the RF signal) can be seen the most clearly.
3. Next, adjust the tangential tilt adjustment screw with a Phillips screwdriver so that the eye pattern (the diamond shape at the center of the RF signal) can be seen the most clearly (Figure 3).
4. Adjust the radial tilt adjustment screw and the tangential tilt adjustment screw again so that the eye pattern can be seen the most clearly. As necessary, adjust the two screws alternately so that the eye pattern can be seen the most clearly.
5. When the adjustment is completed, lock the radial and tangential adjustment screw.

Note:Radial and tangential mean the directions relative to the disc shown in Figure 2.

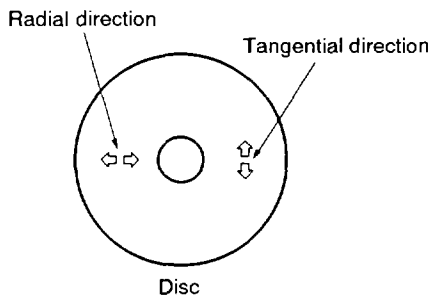
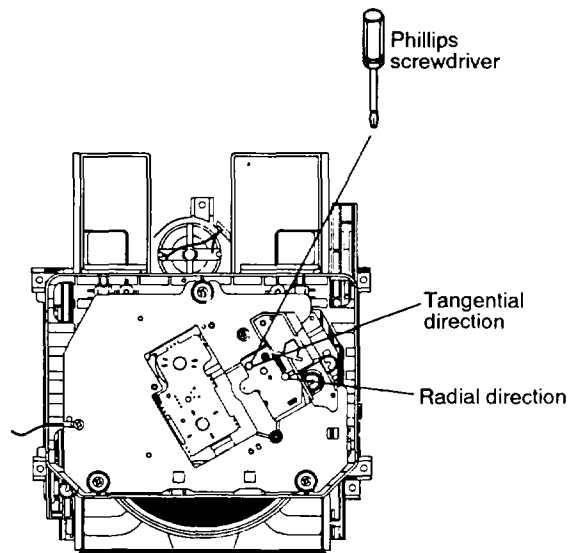
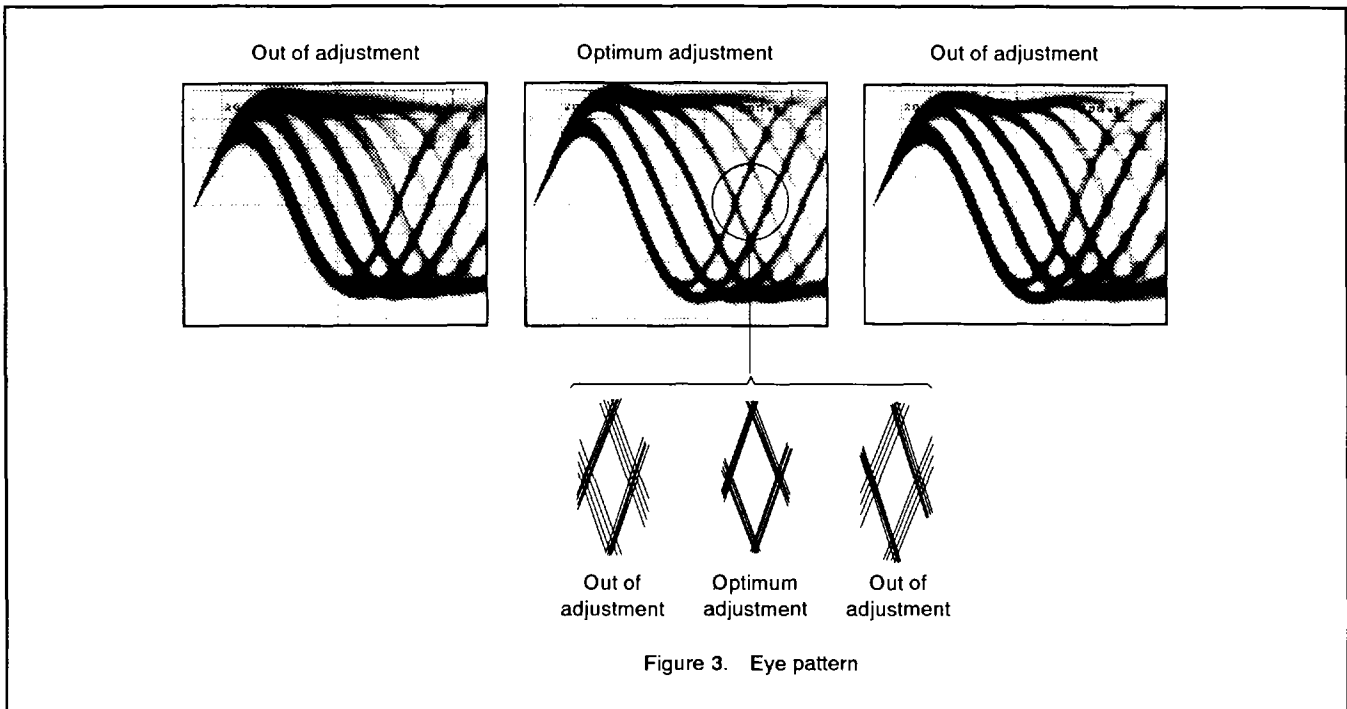

Figure 2



Adjustment locations



4. RF Level Verification

● Objective	To verify the playback RF signal amplitude		
● Symptom when out of adjustment	No play or no search		
● Measurement instrument connections	Connect the oscilloscope to TP1, Pin 1 (RF). [Settings] 50 mV/division 10 ms/division AC mode	● Player state	Test mode, play
		● Adjustment location	None
		● Disc	YEDS-7
[Procedure]			
<ol style="list-style-type: none"> 1. Move the pickup to midway across the disc (R = 35mm) with the TRACK/MANUAL SEARCH FWD $\gg \gg$ or REV $\ll \ll$ key, then press the PGM (PROGRAM) key, the PLAY/PAUSE \triangleright / \square key two times in that order to close the respective servos and put the player into play mode. 2. Verify the RF signal amplitude is $1.2V_{p-p} \pm 0.2V$. 			

5. Focus Servo Loop Gain Adjustment

● Objective	To optimize the focus servo loop gain.		
● Symptom when out of adjustment	Playback does not start or focus actuator noisy.		
● Measurement instrument connections	See figure 4. [Settings] CH1 CH2 20 mV/division 5 mV/division X-Y mode	● Player state	Test mode, play
		● Adjustment location	VR152 (FCS. GAN)
		● Disc	YEDS-7

[Procedure]

1. Set the AF generator output to 1.2 kHz and 1 Vp-p.
2. Press the TRACK/MANUAL SEARCH FWD $\triangleright \triangleright \triangleright$ or REV $\lll \lll \lll$ key to move the pickup to halfway across the disc (R = 35mm), then press the PGM (PROGRAM) key, the PLAY/PAUSE \triangleright / \lll key two times in that order to close the corresponding servos and put the player into play mode.
3. Adjust VR152 (FCS. GAN) so that the Lissajous waveform is symmetrical about the X axis and the Y axis.

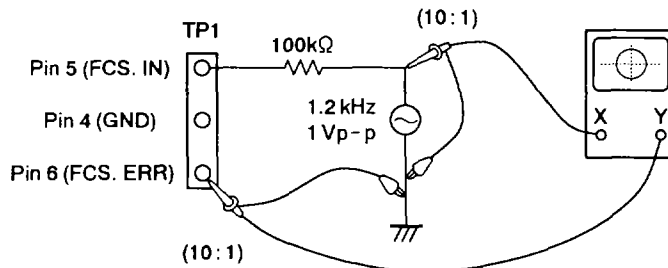
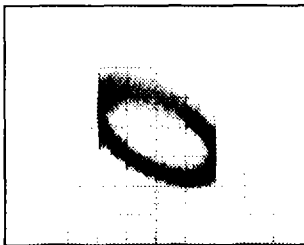

Figure 4

Focus Gain Adjustment



Higher gain



Optimum gain

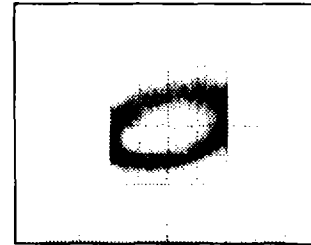

Lower gain

6. Tracking Servo Loop Gain Adjustment

● Objective	To optimize the tracking servo loop gain.		
● Symptom when out of adjustment	Playback does not start, during searches the actuator is noisy, or tracks are skipped.		
● Measurement instrument connections	See Figure 5. [Settings] CH1 CH2 50 mV/division 20 mV/division X-Y mode	● Player state	Test mode, play
		● Adjustment location	VR151 (TRK. GAN)
		● Disc	YEDS-7

[Procedure]

1. Set the AF generator output to 1.2 kHz and 2 Vp-p.
2. Press the TRACK/MANUAL SEARCH FWD $\gg \gg$ or REV $\ll \ll$ key to move the pickup to halfway across the disc (R = 35mm), then press the PGM (PROGRAM) key, the PLAY/PAUSE \triangleright / \square key two times in that order to close the corresponding servos and put the player into play mode.
3. Adjust VR151 (TRK. GAN) so that the Lissajous waveform is symmetrical about the X axis and the Y axis.

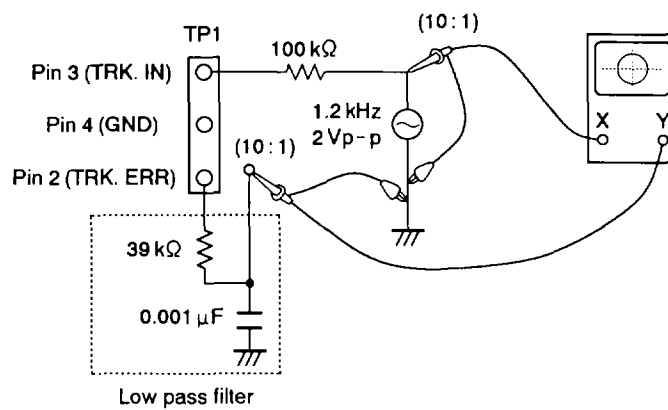

Tracking Gain Adjustment



Higher gain

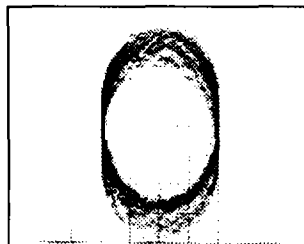

Optimum gain

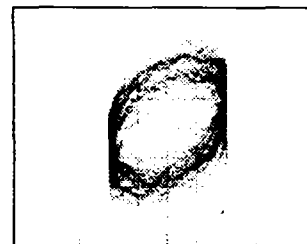

Lower gain

8. FL INFORMATION

● PEL1078 (V701)

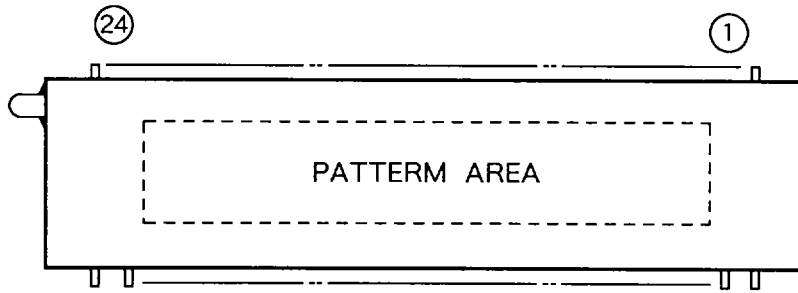

PIN CONNECTION

PIN NO.	22	22	22	21	11	11	11	11	11	11	11	11	11	11	11	11	10	9	8	7	6	5	4	3	2	1
CONNECTION	F	F	N	N	N	P	P	P	P	P	P	P	P	G	G	G	G	G	G	C	P	1	1	1	1	F
	2	2	P	C	C	5	6	7	8	1	2	3	4	7	6	5	4	3	2	1	N	N	F	F	F	F

NOTE
 1) F1, F2 --- Filament
 2) NP ----- No pin
 3) NC ----- No connection
 4) DL ----- Datum Line
 5) 1G~7G --- Grid

GRID ASSIGNMENT

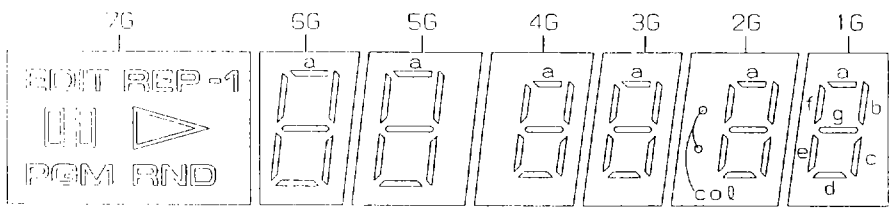

ANODE CONNECTION

	7G	6G	5G	4G	3G	2G	1G
P1	REP	a	a	a	a	a	a
P2	-1	b	b	b	b	b	b
P3	▶	c	c	c	c	c	c
P4	RND	d	d	d	d	d	d
P5	PGM	e	e	e	e	e	e
P6	00	f	f	f	f	f	f
P7	EDIT	g	g	g	g	g	g
P8	-	-	-	-	-	col	-

9. FOR PD-C5/WE, WEWM, WB, PD-C3/WE, WEWM AND WB

CONTRAST OF MISCELLANEOUS PARTS

NOTES:

- Parts marked by "NSP" are generally unavailable because they are not in our Master Spare Parts List.
- The \triangle mark found on some component parts indicates the importance of the safety factor of the part. Therefore, when replacing, be sure to use parts of identical designation.
- Parts marked by "⊙" are not always kept in stock. Their delivery time may be longer than usual or they may be unavailable.

PD-C5/WE, WEWM, WB, PD-C3/WE, WEWM, WB and PD-C5/KU have the same construction except for the following:

Mark	Symbol & Description	Part No.						
		PD-C5/KU	PD-C5/WE	PD-C5/WEWM	PD-C5/WB	PD-C3/WE	PD-C3/WEWM	PD-C3/WB
\triangle	MOTHER BOARD ASSY	PWM1833	PWM1830	PWM1830	PWM1830	PWM1829	PWM1829	PWM1829
\triangle NSP	SUB BOARD ASSY	PWX1314	PWX1311	PWX1311	PWX1311	PWX1310	PWX1310	PWX1310
	└ OPERATION BOARD ASSY	PWZ2681	PWZ2681	PWZ2681	PWZ2681	PWZ2680	PWZ2680	PWZ2680
\triangle	└ SERVO TRANSFORMER BOARD ASSY	PWZ2686	PWZ2683	PWZ2683	PWZ2683	PWZ2682	PWZ2682	PWZ2682
\triangle	Strain relief	CM - 22C	CM - 22B	CM - 22B	CM - 22B	CM - 22B	CM - 22B	CM - 22B
\triangle	AC power cord	PDG1015	PDG1003	PDG1003	PDG1021	PDG1003	PDG1003	PDG1021
\triangle	Power transformer (AC120V)	PTT1296
\triangle	Power transformer (AC220 - 240V)	PTT1295	PTT1295	PTT1295	PTT1236	PTT1236	PTT1236
	Name plate	PAN1296	PAN1296	PAN1296	PAN1296	PAN1297	PAN1297	PAN1297
	Front panel	PNW2482	PNW2360	PNW2360	PNW2360	PNW2381	PNW2381	PNW2381
	65 label	ORW1069
NSP	Rear panel	PNA2055	PNA2040	PNA2058	PNA2139	PNA2054	PNA2059	PNA2140
NSP	Loading mechanism assy	PXA1521	PXA1521	PXA1521	PXA1521	PXA1459	PXA1459	PXA1459
NSP	Cushion	PNM1176	PNM1176	PNM1176	PNM1176
NSP	Angle	PNB1467	PNB1467	PNB1467	PNB1467
NSP	Cord clasper	DNF1128	DNF1128	DNF1128	DNF1128
NSP	Shield tube	PDM1018	PDM1018	PDM1018	PDM1018
	Packing case	PHG2063	PHG2061	PHG2061	PHG2061	PHG2062	PHG2062	PHG2062
	Operating instructions (English)	PRB1204	PRB1204	PRB1204
	Operating instructions (English/French/German/Italian/Dutch/Swedish/Spanish/Portuguese)	PRE1190	PRE1190
	Operating instructions (English/French)	PRF1066	PRF1066
	Caution label HE*	PRW1233	PRW1233	PRW1233	PRW1233
	Caution label*	VRW1094	VRW1094	PRW1018	VRW1094	VRW1094	PRW1018
	Caution label (G)*	VRW - 329	VRW - 329	VRW - 329	VRW - 329	VRW - 329	VRW - 329

* : See page 3

LOADING MECHANISM ASSY

PWX1459 and PWX1521 have the same construction except for the following:

Mark	Symbol & Description	Part No.		Remarks
		PXA1521	PXA1459	
NSP	Turn table assy	PEA1165	PEA1199	
NSP	Tray assy	PXA1397	PXA1449	
NSP	Earth lead unit	PDF1148	PDF1104	

MOTHER BOARD ASSY

PWM1829, PWM1830 and PWM1833 have the same construction except for the following:

Mark	Symbol & Description	Part No.			Remarks
		PWM1833	PWM1830	PWM1829	
	IC401	PD2029A	PD2029A	PD2026B	
	IC405	NJM5532MD	NJM5532MD	NJM4558M	
	L351	LFA3R3J	LFA3R3J	
	C31, C32	CEJA101M16	CEJA101M16	
	C33, C34	CFTXA104J50	CFTXA104J50	
	C431, C432	CEJA101M16	CEJA101M16	CEJA330M16	
	C451	CEJA4R7M50	CEJA4R7M50	
	R351	RS1/10S000J	
	R447, R448	RS1/10S471J	RS1/10S221J	RS1/10S221J	
	R459, R460	RS1/10S271J	RS1/10S820J	RS1/10S820J	
	R461, R462	RS1/10S561J	RS1/10S821J	RS1/10S821J	

OPERATION BOARD ASSY

Although PWZ2680 and PWZ2681 are different in part number, they have the same service parts.

SERVO TRANSFORMER BOARD ASSY

PWZ2683, PWZ2682 and PWZ2686 have the same construction except for the following:

Mark	Symbol & Description	Part No.			Remarks
		PWZ2686	PWZ2683	PWZ2682	
	IC31	ICP – N10	ICP – N10	
	L11	VTH1024	VTH1024	
	C15	CFTXA103J50	CFTXA103J50	CKCYF103Z50	
	C25	CEAS472M16	CEAS472M16	CEAS332M16	
	C26	CEAS472M16	CEAS472M16	CEAS222M16	
	C27	CEAS102M35	CEAS102M35	CEAS471M6R3	

10. PANEL FACILITIES

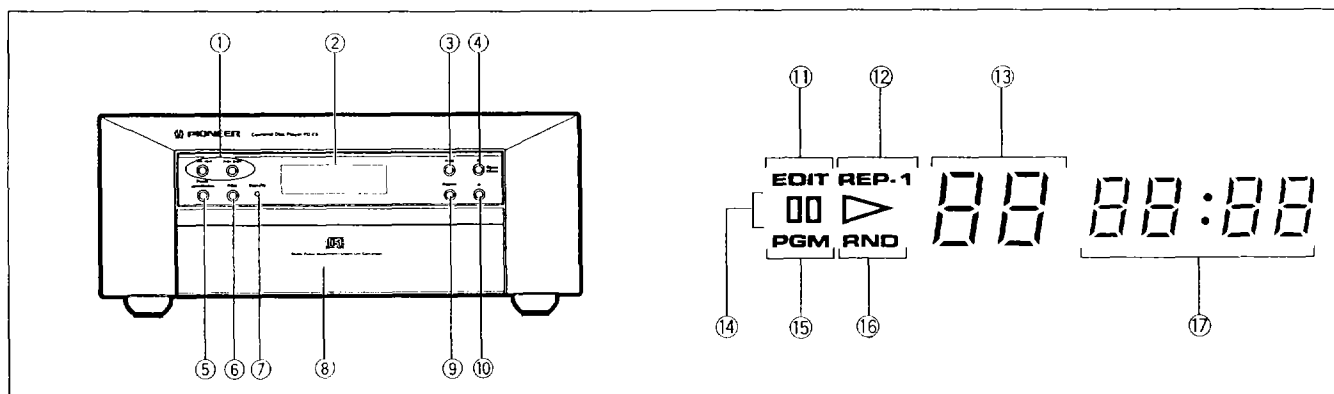

- ① Track/Manual search buttons (◀◀ ◀▶ ▶▶ ▶▶)
- ② Display
- ③ Play/Pause button (▶ ||)
- ④ Open/Close button (▲)
- ⑤ Power standby/on switch
- ⑥ PGM (program) button
- ⑦ Standby indicator
- ⑧ Disc tray
- ⑨ Repeat button
- ⑩ Stop button (■)

Display Section

- ⑪ Lights during automatic program edit.*
- ⑫ Lights during repeat playback.
REP-1: Single-track repeat playback.
REP: All-track (or all program) repeat playback.
- ⑬ Displays the track number.
- ⑭ II: Lights during pause mode.
▶: Lights during playback.
- ⑮ Lights when setting a program, and during program playback.
- ⑯ Lights during random playback.*
- ⑰ Time display
During playback, displays the elapsed time from beginning of the current track.
If the ▶▶▶▶ button is pressed from the stop mode, each track's playing time will be displayed, beginning from track 1 (tracks 30 and higher are not displayed).

*When using this player as part of a PIONEER compact component system:

When the system-control connector on this player is connected to the other components in the system, the remote control unit supplied with the system amplifier can be used to perform the following operations on this component:

Auto program edit:
(Edit button)

When recording a CD onto cassette tape, tape tracks are automatically programmed in the optimum order to fill the cassette tapes without interruption or loss of music programs.

Random playback:
(Random button)

Used to perform playback of the tracks on a CD in random order.

Time display switching:

Allows the time display to be switched as follows:

Elapsed time of currently playing track

Remaining time of currently playing track (does not display for tracks exceeding number 30 on a disc)



Total number of tracks and total playing time on disc (or of all programmed tracks).

Remaining time on disc (or remaining time of programmed tracks; this function does not operate during random playback)



11. SPECIFICATIONS

General

Component type	Compact disc audio system
Usable discs	Standard compact discs
Power	AC 220 – 240 V, 50/60 Hz
Power consumption	14 W
Ambient temperature during operation	+5° C to +35° C
Weight	
PD-C5	3.1 kg
PD-C3	3.0 kg
External dimensions	260 (W) x 110 (H) x 328 (D)
Frequency response	2 Hz – 20 kHz
S/N ratio	
PD-C5	106 dB or more (EIAJ)
PD-C3	98 dB or more (EIAJ)
Dynamic range	95 dB or more (EIAJ)
Channel separation	
PD-C5	100 dB or more (EIAJ)
PD-C3	92 dB or more (EIAJ)
Total harmonic distortion	0.005% or less (EIAJ)
Output voltage	2.0 V
Wow and Flutter	Limit of measurement (± 0.001% W.PEAK) or less (EIAJ)
Channels	2-channel (stereo)

Functions

- Play
- Pause
- Stop
- Track/Manual search
- Repeat (single track, all tracks, program, random*)
- Auto program edit*
- Program playback (24 tracks)
- Random playback*

Accessories

- Audio connection cables 1
- Control cable..... 1
- Operating Instructions 1

NOTE:

Specifications and design subject to possible modifications without notice due to improvements.

*Functions controllable with the remote control unit furnished with the amplifier.